

Midatec

sensing the future

**DETECTION
TECHNOLOGY
FOR INDUSTRY**

ULTRASONIC
ACCESSORIES
INDUCTIVE SENSORS
PHOTOELECTRIC SENSORS
SAFETY SWITCHES
VISION SENSORS
LIGHTING



We make sensors for industry

In pursuit of the perfect solution, Midatec designs, develops and manufactures sensors for industry, continuously striving to offer innovative and reliable products.

Product summary

 <p>Mid+</p>	 <p>MidS+</p>	 <p>MidC</p>	 <p>MidB</p>	 <p>MidL</p>
 <p>MidC/B</p>	 <p>MidS+/B</p>			
 <p>Standard M8 Series</p>	 <p>Standard M12 Series</p>	 <p>Standard M18 Series</p>	 <p>Standard M30 Series</p>	
 <p>OM/18</p>	 <p>OM/32</p>	 <p>OM/DIN</p>	 <p>OM/FR</p>	
 <p>DMS</p>	 <p>DMS/S</p>	 <p>DMS/5</p>	 <p>DMS/M</p>	 <p>RSM 003E1</p>
 <p>SV1</p>	 <p>SVA</p>			
 <p>LMD</p>	 <p>LMD/S</p>	 <p>LMD/SD</p>	 <p>LMD/C</p>	

Table of Contents

Ultrasonic accessories	4	Safety switches	52
Distance sensors		Safety switches	
Mid+ Series M30 barrel housing	8	DMS Series	54
MidS+ Series M18 barrel housing	12	DMS/S Series	56
MidC Series Square housing	16	DMS/S Series	58
Fork sensors		Door locking protection systems	
MidB Series Alignment detector	20	DMS/M Series	60
MidL Series Label and joint detection	22	Safety relays	
Ultrasonic through-beam sensors		RSM 003E1 Emergency stop device	64
MidC/B Series Rectangular housing	24	Smart vision	66
MidS+/B Series M18 barrel housing	25	SV1 Series	68
Programming		SVA Software Smart Vision Assistant	74
TLK Case Programming and adjustment kit	28	Lighting and industrial signalling	84
MidConnect Configuration and measurement control software	29	Lighting for machines	
Inductive sensors	30	LMD Series	86
Proximity sensors		Signalling	
Basic Series	32	LMD/S Series	88
M8	34	LMD/SD Series DOMO LED	90
M12	35	LMD/C Series Combined lighting	92
M18	36	Accessories	94
M30	37	TD001 Sensor tester	94
Photoelectric sensors	38	Mounting brackets	95
Distance sensors		Accessories for ultrasonic sensors	96
OM/18 Series M18 barrel housing	40	Deflectors	96
OM/32 Series Rectangular housing	42	Soundpipes	96
Fibre optic		Lighting accessories	97
OM/DIN Series Fibre-optic amplifier	44	Brackets	97
Fibre optics	46	Diffusers	97
Cutting accessories	47	Connectors	98
Fibre-optic adapter	47	M8 connectors	98
Reflectors	47	M12 connectors	99
Fork through-beam sensors			
OM/FR Series	48		

ULTRANSONIC SENSORS



Mid+ Series

M30 barrel



MidS+ Series

M18 barrel



MidC Series

Compact square



MidB Series

Alignment



MidL Series

Label detector



MidS+/B Series

Through-beam barrel housing



MidC/B Series

Through-beam rectangular housing

Technology

Main advantages

These are proximity detectors without any physical contact that detect objects from a distance by emitting a sound and measuring the time the signal takes to return.

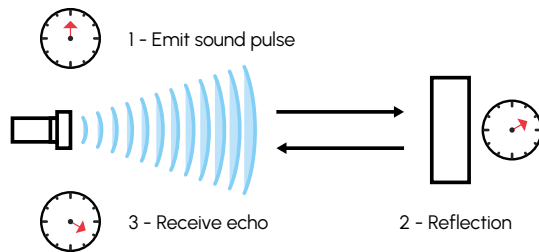

As the distance to the object is measured by the path taken by the sound and thus does not measure intensity, ultrasonic sensors are not sensitive to background noise.

The objects detected can be solid, liquid and in powder form. All that is required is that the sound waves be reflected towards the sensor. Sensors

Because of their capacity to measure distances and accurately and reliably detect objects in different environments, ultrasonic sensors serve a wide range of industrial uses. The following are some of the most common:

operate in dusty and mist coat paint atmospheres. Fine particle deposits on the sensor membrane do not affect measurements.

Among the benefits of using ultrasonic sensors are:

- ▶ Operation in hostile environments, such as those where there is dust, humidity or chemical products
- ▶ Accuracy when measuring objects at a long distance away
- ▶ Capacity to measure moving objects
- ▶ No physical contact is required with the object to be measured
- ▶ Wide range of industrial uses.

Ultrasonic sensors can be used for diverse industrial purposes, such as measuring liquid levels in tanks, detecting objects on production lines and controlling material levels in silos, among others. Moreover, these sensors resist adverse environmental conditions like humidity, extreme temperatures and vibrations, which makes them ideal for use in industrial settings.

Applications

Liquid level measurement

Ultrasonic sensors are frequently used to measure liquid levels in tanks and vessels. They can detect the level of a liquid and send a signal to a controller to adjust the liquid supply.

Moving object detection

Ultrasonic sensors are used to detect moving objects. For example, when automating factory processes they can be used to detect objects that are passing through the production line.

Production process control

Ultrasonic sensors are used in production processes to measure the thickness of materials and to ensure that they meet production specs.

Distance measurement

Ultrasonic sensors are used to measure distances in several situations, ranging from measuring the distance between objects on a production line to measuring the distance between a vehicle and an obstacle.

Object detection in hostile environments

Ultrasonic sensors are very useful in harsh environments where optical or electronic sensors fail to work properly owing to factors such as the presence of dust, humidity or pollutants.

Operating modes and uses

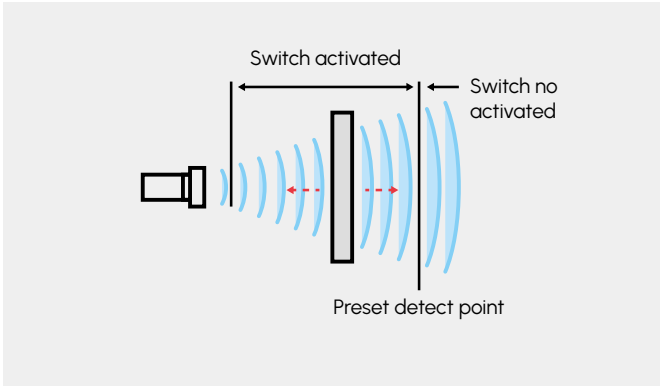

Direct reflection

In direct reflection or direct energy reflection mode, the sensor has an emitter and receiver in the same housing, which makes this a versatile and cost-effective solution. Easy to install, no reflector is required.

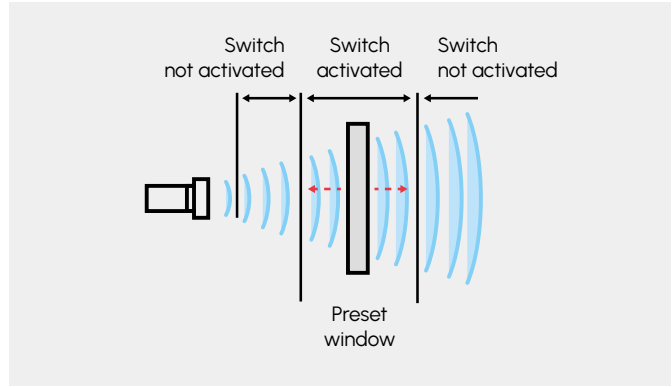

Window operating mode

In this case, the output switch is only triggered when the object enters the window defined by two limits. For example, this makes it possible to ensure that only bottles of the right size are found in a box. Those that are too tall or short are eliminated.

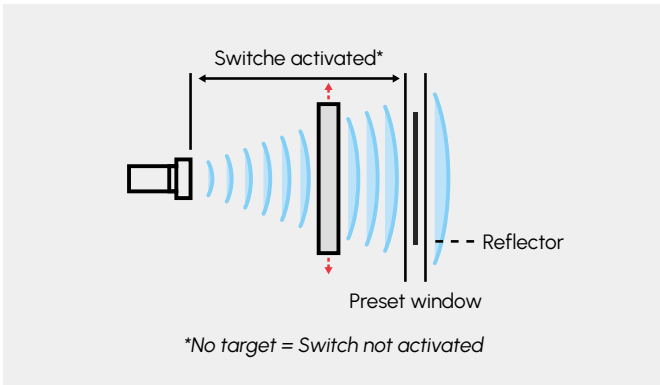

Reflective barrier - Mirror

As is the case with direct reflection, the sensor has a transmitter and receiver in the same housing, but in this case the operating principle makes use of a high-performance, fixed reflector that ensures the return of the light beam. When the object blocks the said light beam, the intensity of the light received drops and the sensor is activated. The relative high level of light reflected enables the sensor to reach longer distances.

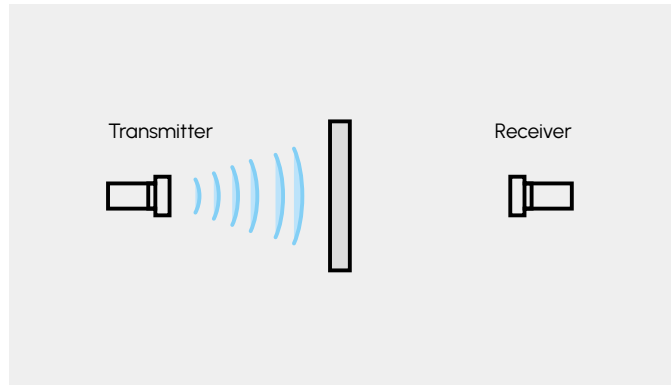

Barrier

The transmitter and receiver are housed in two separate housings. This means that long distances can be measured and high switching frequencies used. This operating principle means that detection is not greatly affected by the colour, brightness, size or shape of the object to be detected.

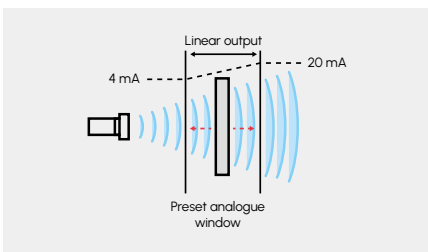

Analogue output ultrasonic sensors

These indicate the distance measured as a voltage in proportion to the distance (0-10 V) and not as current in proportion to the distance (4-20 mA). Lower and upper window limits can be set to the characteristic analogue curve, as well as to rise and drops. Resolution will vary depending on the type of sensor used and the size of the window.

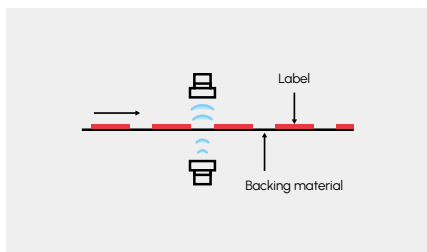

Labels and joints

These work to the same principle as the ultrasonic control of double sheets. The sensor detects, or not, as the case may be, the label on the support material, thus enabling its positioning in the labelling system. Label sensors need to learn about the support material and/or label for optimum performance.

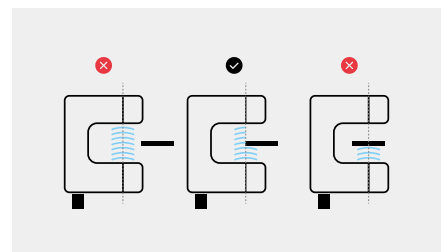

Alignment

Fork or slot sensors also work very well as through-beam devices. They are used to regulate strips or bands and emit a 0-10 V or 4-20 mA signal in proportion to the position from the edge of the strip.

Synchronisation and multiplexing

Synchronisation and multiplexing are two techniques that can be used with ultrasonic sensors to enhance their object detection performance and efficiency.

Synchronisation and multiplexing are two important techniques that can be used with ultrasonic sensors

to enhance their object detection efficiency and accuracy. Synchronisation guarantees coordinated transmission and reception times, while multiplexing makes it possible for several sensors to share a communication channel without interfering with each other (crosstalk).

Synchronisation

This technique is used for the simultaneous triggering of up to a maximum of 10 sensors.

It makes the detection area bigger by making the sensor signals positively interfere with those of others, but not randomly.

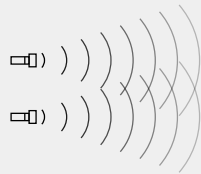

The synchronisation signal will always deactivate when the device is connected via TLKUSB.

Mounting

Connect all 5 synchronisation pins together.

Activate synchronisation in the sensors. It comes activated by default. Make sure that this option has been checked.

Unsynchronised

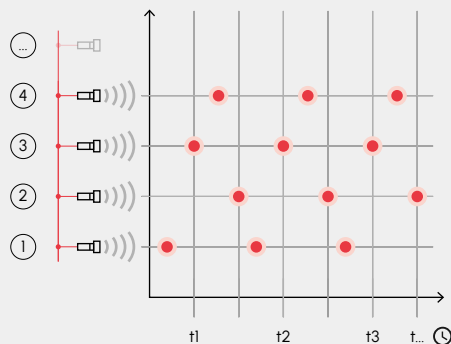

Synchronised

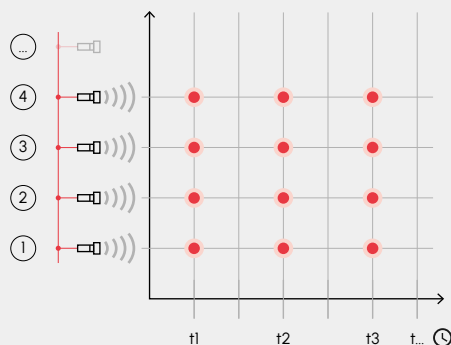

Multiplexing

Multiplexing ultrasonic sensors makes it possible to emit ultrasonic bursts at staggered intervals. This prevents interference between the sensors, without having to maintain a minimum distance between them. Given that the sensors are activated sequentially, the response/reaction time increases with each sensor that is added to the multiplex matrix.

If zero interference is required between closely fitted sensors (less than the recommended distances), multiplexing must be activated. This serves to establish a trigger order for the sensors that will take measurements independently, but in sequence.

Up to a maximum of 10 sensors together.

There are no interferences between sensors with a different trigger order.

Switching frequency is reduced in accordance with the turns established.

Filters are also affected given that trigger frequency varies.

Several sensors can be included in each trigger turn as long as the maximum number of multiplexed sensors is respected.

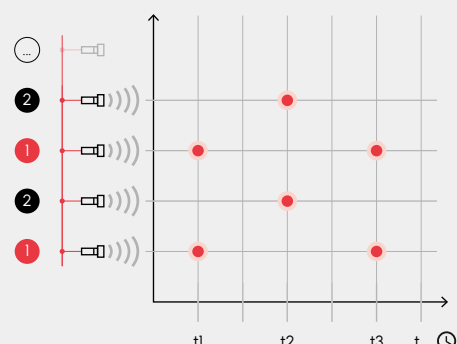

Mid+ Series



M30 barrel housing

Provides a high level of detection accuracy and reliable performance in industrial and highly demanding environments.

Flush mounted transducer

This eliminates all areas susceptible to dust accumulation, thereby obtaining enhanced performance even in very dirty conditions

Midatec Mid+ sensors come with a three, pushbutton display that characterises the series, which enables efficient handling and access to all configuration settings.

Outputs

Units with any combination of PNP and NPN digital outputs and analogue outputs in voltage and current

Housing available in industrial environment resistant materials

- **Nickel-plated brass** for standard uses
- **Stainless steel** for more demanding uses given its high resistance and durability

Parameterisation

Using the TLKUSB device and MidConnect software

Synchronisation





To simultaneously trigger two or more sensors connected via pin 5.







Multiplexing

If you want to cut out interferences between sensors fitted very close to each other (see recommended distances). In this way you can establish a trigger order for the sensors that will take measurements independently, but in sequence.



General characteristics

	Protection rating	IP67
	Housing material (Depending on the version)	Nickel-plated brass and PBT Stainless steel and PBT
	Detection face material	Epoxy resin and polyurethane foam
	Adjustment elements	3 Pushbutton + LED indicators
	Resolution	0.19 mm

	Temperature offset	Yes, 1% drift
	Function indicator	Power: Green LED Output: Red LED
	Supply voltage	10-30 Vdc Reverse polarity protection
	Temperature range	-25 ... 70 °C
	Connections	5-pin, M12x1 connector
	Programming	TLKUSB/MidConnect

Midatec Mid+ series sensors cover ranges from 30 mm to 8 m.

Object detection in hostile environments: Ultrasonic sensors are very useful in harsh environments where optical or electronic sensors fail to work properly owing to environment factors such as the presence of dust, humidity or pollutants.

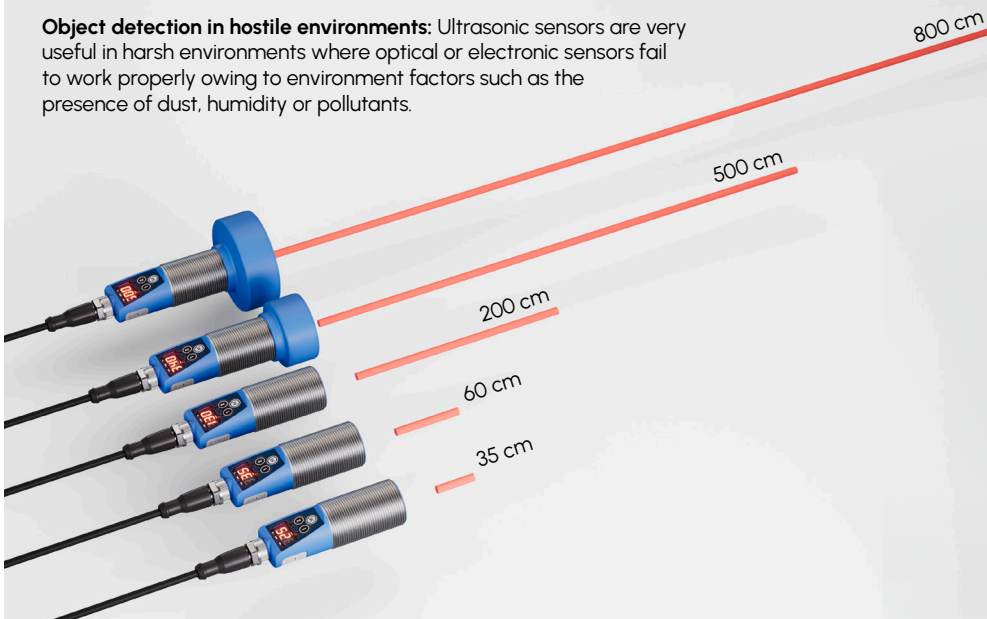

Liquid level measurement:
Ultrasonic sensors are frequently used to measure liquid levels in tanks and vessels.



Mid+ 025 / 035 / 130

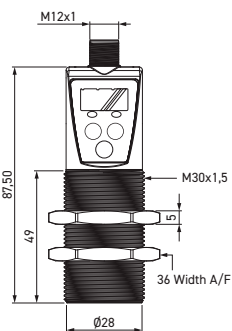

Mid+ 340

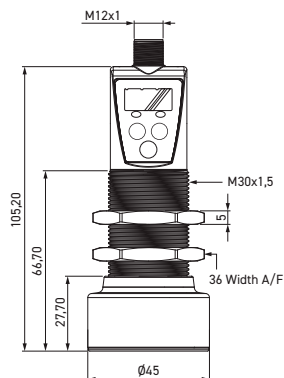

Mid+ 600

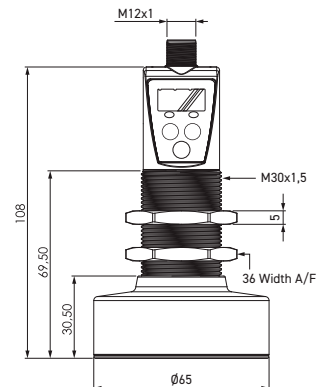

Mid+ Series

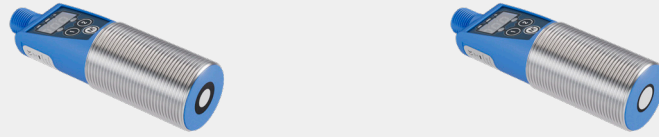

	Mid+ 025	Mid+ 035
Maximum Range (Sn)	350 mm	600 mm
Real Range (Sr)	250 mm	350 mm
Blind zone	30 mm	60 mm
Ultrasonic frequency	320 kHz	400 kHz
Max. switching frequency	25 Hz	8 Hz
Switching hysteresis	3 mm	5 mm
Housing material	Nickel-plated Stainless steel	Nickel-plated Stainless steel

Reference	Output
Mid+ AN025CI2	Analogue output + NPN
Mid+ AN025CI2A	Analogue output + NPN
Mid+ AP025CI2	Analogue output + PNP
Mid+ AP025CI2A	Analogue output + PNP
Mid+ AX025CI2	Analogue output
Mid+ AX025CI2A	Analogue output
Mid+ NN025CI2	2 NPN digital outputs
Mid+ NN025CI2A	2 NPN digital outputs
Mid+ PP025CI2	2 PNP digital outputs
Mid+ PP025CI2A	2 PNP digital outputs
Mid+ XN025CI2	NPN digital output
Mid+ XN025CI2A	NPN digital output
Mid+ XP025CI2	PNP digital output
Mid+ XP025CI2A	PNP digital output

Reference	Output
Mid+ AN035CI2	Analogue output + NPN
Mid+ AN035CI2A	Analogue output + NPN
Mid+ AP035CI2	Analogue output + PNP
Mid+ AP035CI2A	Analogue output + PNP
Mid+ AX035CI2	Analogue output
Mid+ AX035CI2A	Analogue output
Mid+ NN035CI2	2 NPN digital outputs
Mid+ NN035CI2A	2 NPN digital outputs
Mid+ PP035CI2	2 PNP digital outputs
Mid+ PP035CI2A	2 PNP digital outputs
Mid+ XN035CI2	NPN digital output
Mid+ XN035CI2A	NPN digital output
Mid+ XP035CI2	PNP digital output
Mid+ XP035CI2A	PNP digital output

Detection zone

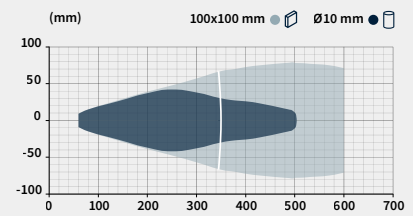
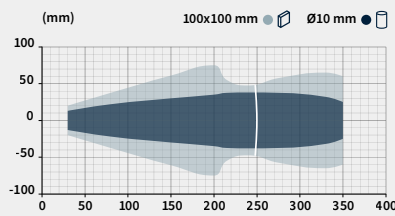

Analogue output

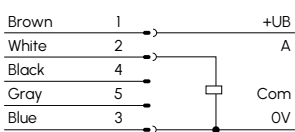

Analogue output + PNP

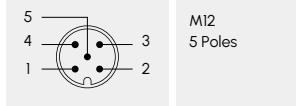
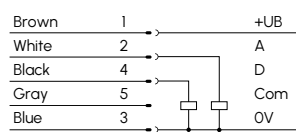

Analogue output + NPN

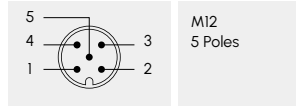
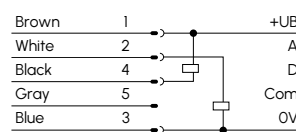

PNP digital output

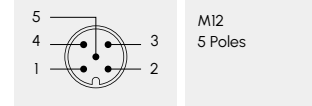
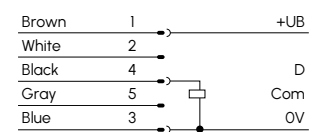

Technical specifications



Mid+ 130	Mid+ 340	Mid+ 600
2000 mm	5000 mm	8000 mm
1300 mm	3400 mm	6000 mm
200 mm	350 mm	600 mm
200 kHz	120 kHz	80 kHz
8 Hz	4 Hz	3 Hz
20 mm	50 mm	100 mm

Nickel-plated Stainless steel Nickel-plated Stainless steel Nickel-plated Stainless steel

Reference	Output
Mid+ ANI30C12	Analogue output + NPN
Mid+ ANI30C12A	Analogue output + NPN
Mid+ API30C12	Analogue output + PNP
Mid+ API30C12A	Analogue output + PNP
Mid+ AXI30C12	Analogue output
Mid+ AXI30C12A	Analogue output
Mid+ NNI30C12	2 NPN digital outputs
Mid+ NNI30C12A	2 NPN digital outputs
Mid+ PPI30C12	2 PNP digital outputs
Mid+ PPI30C12A	2 PNP digital outputs
Mid+ XNI30C12	NPN digital output
Mid+ XNI30C12A	NPN digital output
Mid+ XPI30C12	PNP digital output
Mid+ XPI30C12A	PNP digital output

Reference	Output
Mid+ AN340C12	Analogue output + NPN
Mid+ AN340C12A	Analogue output + NPN
Mid+ AP340C12	Analogue output + PNP
Mid+ AP340C12A	Analogue output + PNP
Mid+ AX340C12	Analogue output
Mid+ AX340C12A	Analogue output
Mid+ NN340C12	2 NPN digital outputs
Mid+ NN340C12A	2 NPN digital outputs
Mid+ PP340C12	2 PNP digital outputs
Mid+ PP340C12A	2 PNP digital outputs
Mid+ XN340C12	NPN digital output
Mid+ XN340C12A	NPN digital output
Mid+ XP340C12	PNP digital output
Mid+ XP340C12A	PNP digital output

Reference	Output
Mid+ AN600C12	Analogue output + NPN
Mid+ AN600C12A	Analogue output + NPN
Mid+ AP600C12	Analogue output + PNP
Mid+ AP600C12A	Analogue output + PNP
Mid+ AX600C12	Analogue output
Mid+ AX600C12A	Analogue output
Mid+ NN600C12	2 NPN digital outputs
Mid+ NN600C12A	2 NPN digital outputs
Mid+ PP600C12	2 PNP digital outputs
Mid+ PP600C12A	2 PNP digital outputs
Mid+ XN600C12	NPN digital output
Mid+ XN600C12A	NPN digital output
Mid+ XP600C12	PNP digital output
Mid+ XP600C12A	PNP digital output

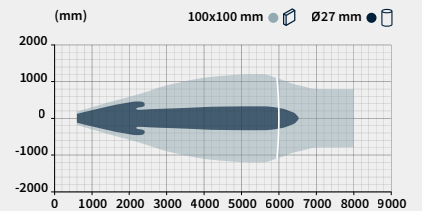
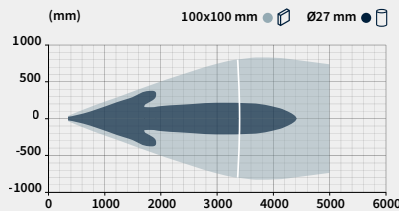
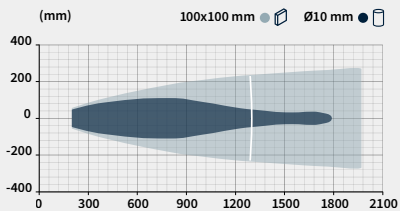

NPN digital output

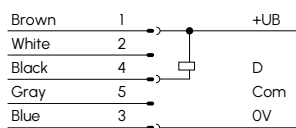

Dual PNP digital output

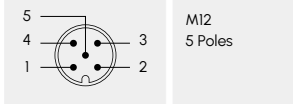
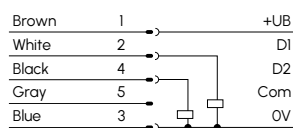

Dual NPN digital output

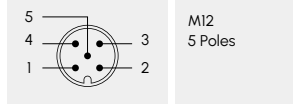
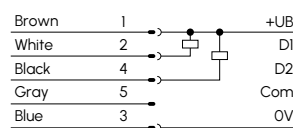

MidS+ Series



Four models to cover distances up to 1.5 m, with M18 housing.

Parameterisation using the TLKUSB device and MidConnect software

Synchronisation To simultaneously trigger two or more sensors connected via pin 5.

Multiplexing If you want to cut out interferences between sensors fitted very close to each other (see recommended distances). In this way you can establish a trigger order for the sensors that will take measurements independently, but in sequence.



Outputs

Both models have versions with two outputs, analogue and digital, on the same sensor.











Function indicators for power and outputs

Housing made of stainless steel for use in extreme environmental conditions with heavy mechanical stress.

Flush mounted transducer

This eliminates all areas susceptible to dust accumulation, thereby obtaining enhanced performance even in very dirty conditions

General characteristics

	Protection rating	IP67		Function indicator	Power: Green LED Output: Red LED
	Detection face material	Epoxy resin and polyurethane foam		Supply voltage	10-30 Vdc 15-30 Vdc (Voltage output)
	Adjustment elements	Teach-In (pin 5)		Temperature range	-25 ... 70 °C
	Resolution	0.19 mm		Connections	5-pin, M12x1 connector
	Temperature offset	Yes, 1% drift		Programming	TLKUSB/MidConnect

Four models to cover distances up to 1.5 m. with M18 housing.

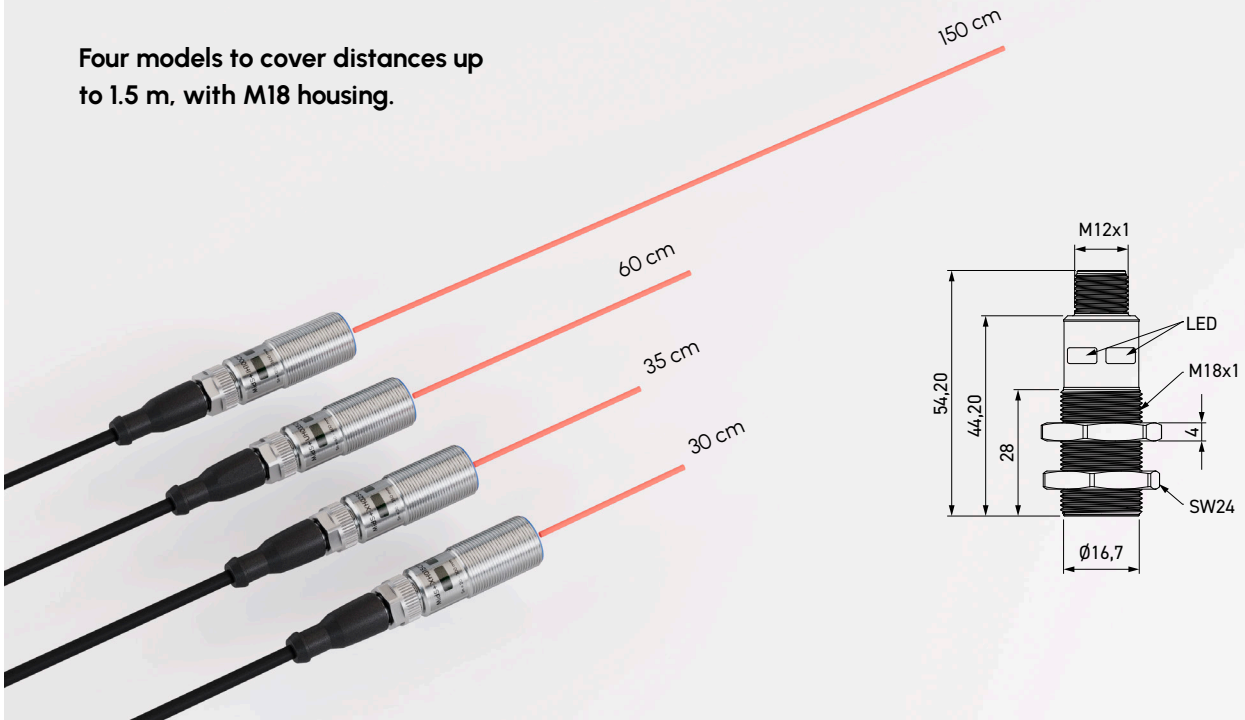

Moving object detection

Ultrasonic sensors are used to detect moving objects. For example, when automating factory processes they can be used to detect objects that are passing through the production line.

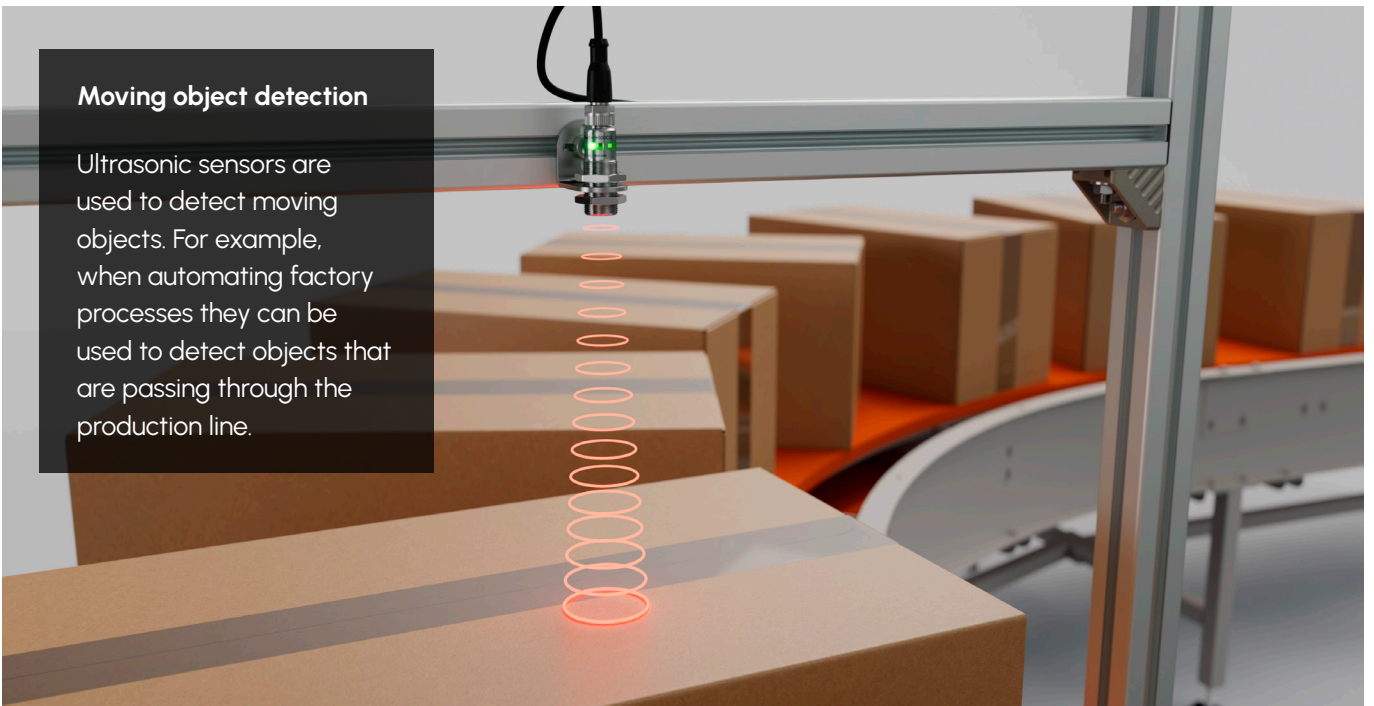

MidS+ Series

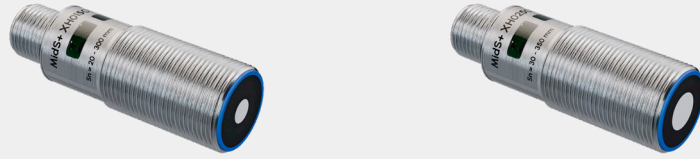

	MidS+ 015	MidS+ 025
Maximum Range (Sn)	300 mm	350 mm
Real Range (Sr)	150 mm	250 mm
Blind zone	30 mm	30 mm
Ultrasonic frequency	380 kHz	320 kHz
Max. switching frequency	25 Hz	25 Hz
Switching hysteresis	2 mm	3 mm

Reference	Output
MidS+ IH015C12	Current Output + Push-Pull
MidS+ IX015C12	Current Output
MidS+ UH015C12	Voltage Output + Push-Pull
MidS+ UX015C12	Voltage Output
MidS+ XH015C12	Digital Push-Pull output

Reference	Output
MidS+ IH025C12	Current Output + Push-Pull
MidS+ IX025C12	Current Output
MidS+ UH025C12	Voltage Output + Push-Pull
MidS+ UX025C12	Voltage Output
MidS+ XH025C12	Digital Push-Pull output

Detection zone

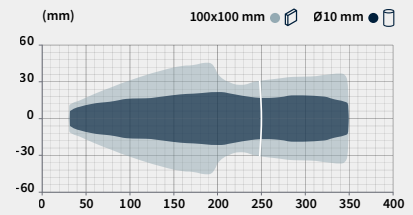
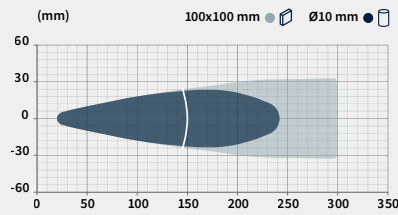

Digital Push-Pull output

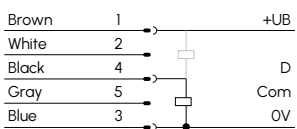

Dual voltage output + Push-Pull

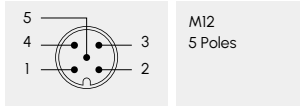
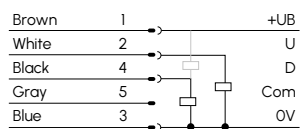

Voltage output

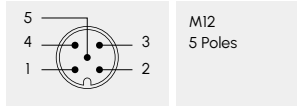
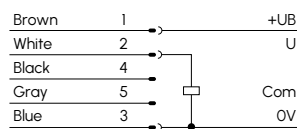

Current output

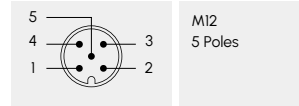
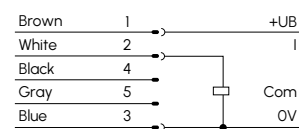

Technical specifications



MidS+ 035		MidS+ 100		
600 mm		1500 mm		
350 mm		1000 mm		
60 mm		120 mm		
200 kHz		190 kHz		
8 Hz		10 Hz		
5 mm		10 mm		
Reference	Output	Reference	Output	
MidS+ IH035C12	Current Output + Push-Pull	MidS+ IH100C12	Current Output + Push-Pull	
MidS+ IX035C12	Current Output	MidS+ IX100C12	Current Output	
MidS+ UH035C12	Voltage Output + Push-Pull	MidS+ UH100C12	Voltage Output + Push-Pull	
MidS+ UX035C12	Voltage Output	MidS+ UX100C12	Voltage Output	
MidS+ XH035C12	Digital Push-Pull output	MidS+ XH100C12	Digital Push-Pull output	
<p>(mm) 100x100 mm \varnothing10 mm </p>		<p>(mm) 100x100 mm \varnothing10 mm </p>		

Dual current output + Push-Pull

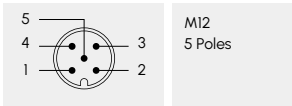
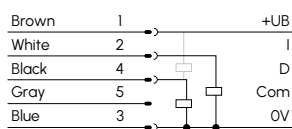

MidC Series



Five different models in rectangular housing, which cover distances of up to 1 m and frequencies of 250 Hz

The quick mounting format means this is an excellent solution for short distance uses.

Output

There are models with digital push-pull output and analogue voltage or current outputs.

Flush mounted transducer







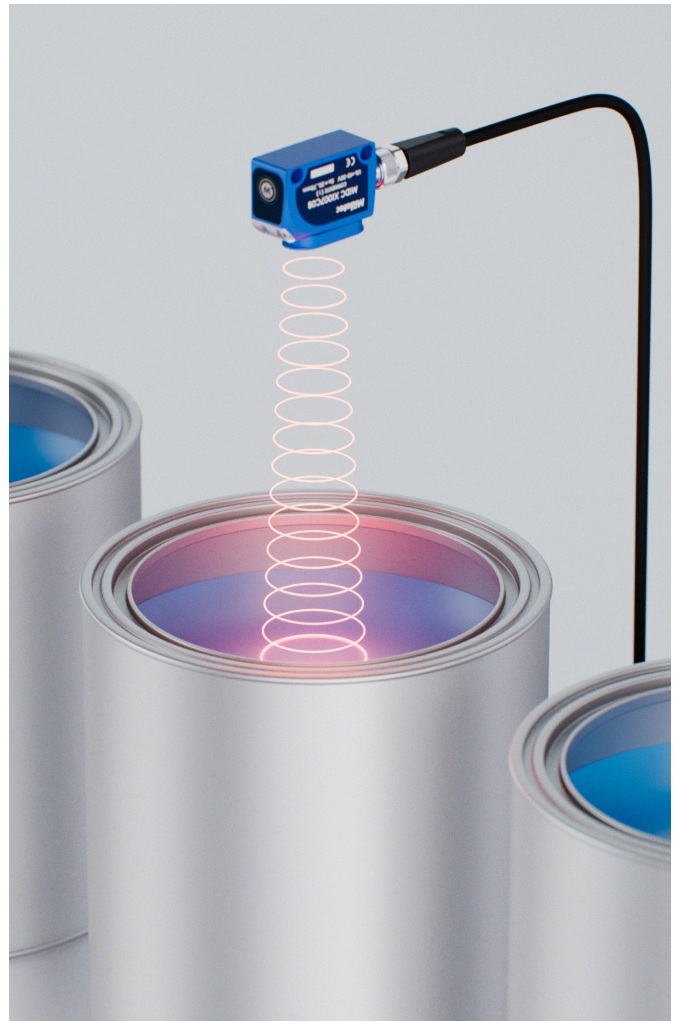

This eliminates all areas susceptible to dust accumulation, thereby obtaining enhanced performance even in very dirty conditions.

Built-in pushbutton

Facilitates device programming. LEDs indicate output status.



General characteristics

	Protection rating	IP67		Adjustment elements	1 Teach-In Pushbutton
	Housing material	ABS		Function indicator	Power: Green LED Output: Red LED
	Detection face material	Epoxy resin and polyurethane foam		Switching hysteresis	2 mm
	Resolution	0.085 mm		Temperature range	-25 ... +70 °C
				Connections	4-pin, M8x1 connector

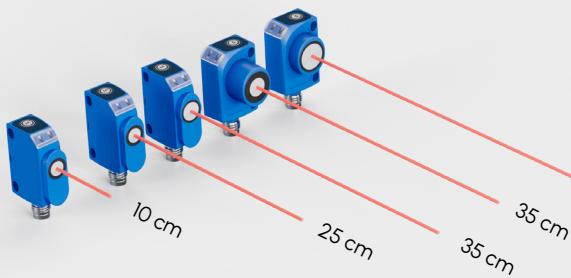

Light, compact models, making them easy to fit and handle for different uses.

Housing design and mounting are compatible with many optical sensors. This makes it easier to change over to an ultrasonic sensor for critical uses.

MidC 007 /015

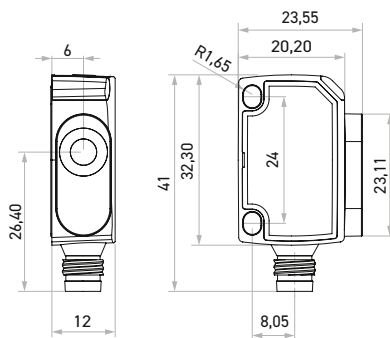

MidC 024

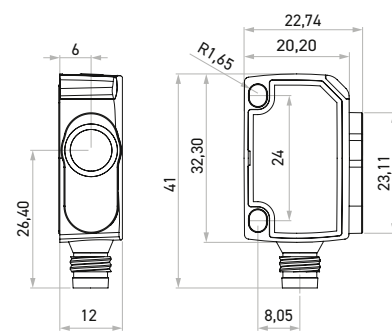

MidC 025

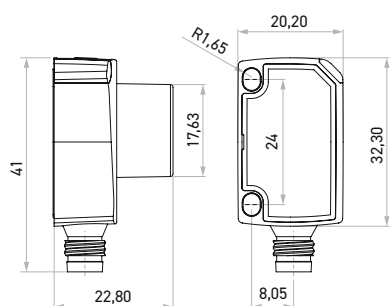

MidC 070

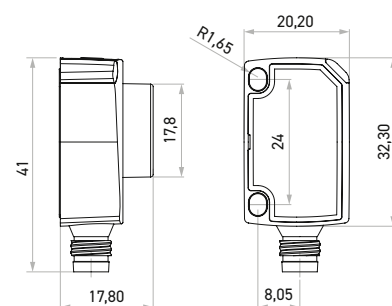

MidC Series

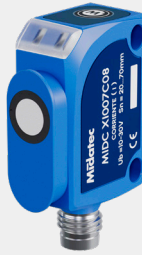

	MidC 007	MidC 015												
Maximum Range (Sn)	100 mm	250 mm												
Real Range (Sr)	70 mm	150 mm												
Blind zone	20 mm	20 mm												
Ultrasonic frequency	380 kHz	380 kHz												
<i>With digital output</i>														
Max. switching frequency	250 Hz	25 Hz												
Switching hysteresis	2 mm	2 mm												
	<table border="1"> <thead> <tr> <th>Reference</th> <th>Output</th> </tr> </thead> <tbody> <tr> <td>MidC XH007C08</td> <td>Digital Push-Pull output</td> </tr> </tbody> </table>	Reference	Output	MidC XH007C08	Digital Push-Pull output	<table border="1"> <thead> <tr> <th>Reference</th> <th>Output</th> </tr> </thead> <tbody> <tr> <td>MidC XH015C08</td> <td>Digital Push-Pull output</td> </tr> <tr> <td>MidC XI015C08</td> <td>Current Output</td> </tr> <tr> <td>MidC XU015C08</td> <td>Voltage Output</td> </tr> </tbody> </table>	Reference	Output	MidC XH015C08	Digital Push-Pull output	MidC XI015C08	Current Output	MidC XU015C08	Voltage Output
Reference	Output													
MidC XH007C08	Digital Push-Pull output													
Reference	Output													
MidC XH015C08	Digital Push-Pull output													
MidC XI015C08	Current Output													
MidC XU015C08	Voltage Output													
Detection zone														

Digital Push-Pull output

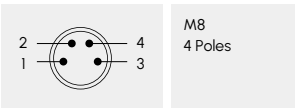
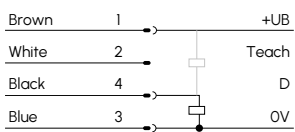

Analogue voltage output

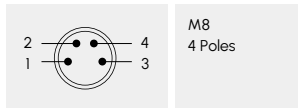
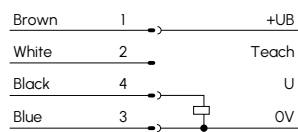

Analogue current output

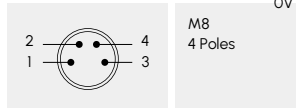
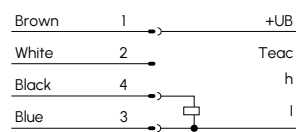

Technical specifications



MidC 024		MidC 025		MidC 070	
350 mm		350 mm		1000 mm	
240 mm		250 mm		700 mm	
50 mm		30 mm		120 mm	
500 kHz		320 kHz		300 kHz	
25 Hz		31 Hz		11 Hz	
2 mm		2 mm		2 mm	
Reference	Output	Reference	Output	Reference	Output
MidC XH024C08	Digital Push-Pull output	MidC XH025C08	Digital Push-Pull output	MidC XH070C08	Digital Push-Pull output
MidC XI024C08	Current Output	MidC XI025C08	Current Output	MidC XI070C08	Current Output
MidC XU024C08	Voltage Output	MidC XU025C08	Voltage Output	MidC XU070C08	Voltage Output

(mm) 100x100 mm Ø10 mm

(mm) 100x100 mm Ø10 mm

(mm) 100x100 mm Ø10 mm

MidB Series

Alignment detector



These type of sensors are designed to detect edges and to align materials like paper, cardboard and plastic film, whether opaque or transparent and no matter what the colour.

Alignment sensors

Fork-like alignment sensors equipped with ultrasonic technology are accurate and reliable devices that are used to ensure accurate alignment of a moving strip for a wide range of industrial uses.

They are normally used in the printing industry, where they are used to square the paper or plastic strip during the printing process. They are also used in the making of textiles and to produce film and plastic sheets to ensure accurate strip alignment.

They come with two output combinations:

Digital + analogue and 2xdigital. The digital output can be PNP or NPN, while the analogue output can be programmed for voltage or current.

Teach-In

Simple adjustment using in-built pushbutton.

This facilitates device calibration, enabling adjustment of work points as well as output characteristics.

Three LEDs indicate position inside the detection range.





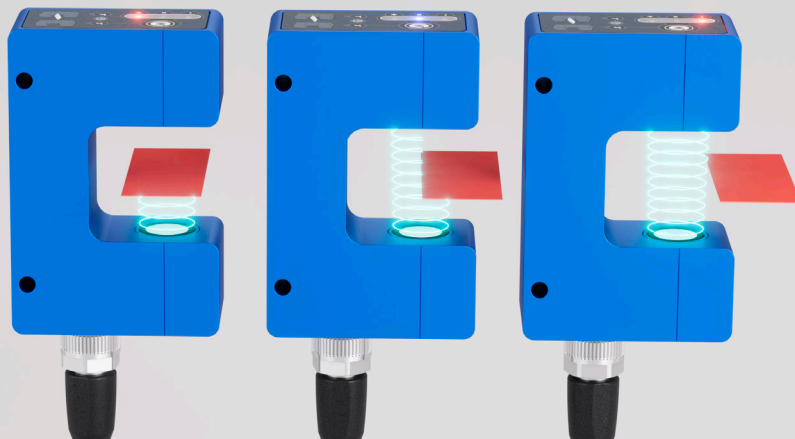

Operation

Any material that enters the sensitive area causes attenuation of the signal picked up at the receiver. This attenuation is measured very accurately and indicates the depth of the material in the sensitive area.



General characteristics

	Protection rating as per EN 60529	IP67
	Housing material	Anodised aluminium. POM and PBT plastic parts
	Detection face material	Epoxy resin and polyurethane foam
	Adjustment elements	Teach-In using pushbutton
	Function indicator	Centre position: Blue LED Off-centre: 2 Amber LEDs
	Operating range	8 mm (± 4 mm)
	Resolution	0.025 mm

	Blind zone	7 mm in front of the transmitter and receiver
	Temperature offset	Yes, 1% drift
	Transducer frequency	190 kHz
	Supply voltage	12-30 Vdc Reverse polarity protection
	Temperature range	-5 ...60 °C
	Connections	5-pin, M12x1 connector

Reference	Output type	Exit 1	Exit 2
MidB AP33C12	Analogue output + PNP	U: 0-10 V (RL>100 K) UB≥15 Vdc I: 4-20 mA (RL<500 Ω)	PNP, I mA _x < 200 mA NO/NC Adjustable contact
MidB AN33C12	Analogue output + NPN	U: 0-10 V (RL>100 K) UB≥15 Vdc I: 4-20 mA (RL<500 Ω)	NPN I mA _x < 200 mA NO/NC Adjustable contact
MidB PP33C12	2 PNP digital outputs	PNP, I mA _x < 200 mA NO/NC Adjustable contact Short-circuit protection	PNP, I mA _x < 200 mA NO/NC Adjustable contact
MidB NN33C12	2 NPN digital outputs	NPN I mA _x < 200 mA NO/NC Adjustable contact Short-circuit protection	NPN I mA _x < 200 mA NO/NC Adjustable contact

High precision: These are high precision devices and can detect strip shift to a few millimetres. This ensures accurate strip alignment and reduces the amount of material loss caused by misalignment.

Wide range of uses: These sensors have a wide range of industrial uses, from printing to textile and plastic film production.

Easy to install: They are easy to install and take up little space. Moreover, they can be easily integrated into existing control systems.

No physical contact required: This reduces sensor wear and tear and maintenance.

Reliable: They have a long service life. Moreover, they are highly resistant to vibration and adverse environmental conditions.

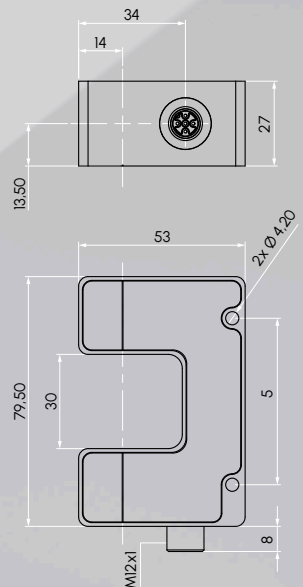

Dual PNP digital output

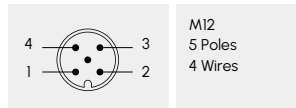
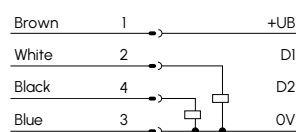

Dual NPN digital output

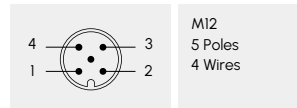
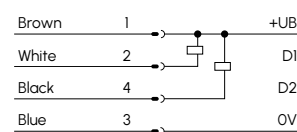

Analogue output + PNP

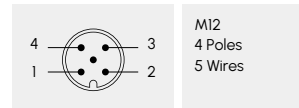
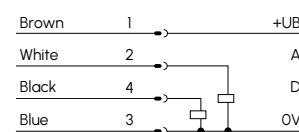

Analogue output + NPN

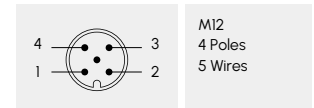
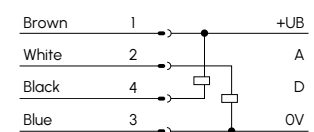

MidL Series

Label and joint detector



Three Teach-In methods and a response time of $< 300 \mu\text{s}$ for high speed work

Label detectors

These work as an ultrasonic field generated by an emitter and picked up by a receiver located on each one of the fork arms.

Any material that enters the sensitive area causes attenuation of the signal picked up at the receiver. This attenuation is accurately measured by the internal electronics, which tells you whether there is material in the sensitive area, and if there is nothing it can distinguish whether only the label holder is present or a strip or if there is a label or strip joint.

Applications

It is particularly useful for detecting materials like paper, transparent, metallic plastic and metallic or plastic tapes.

High-speed label processes

Transparent labels

Opaque labels



The built-in pushbutton enables optimal device calibration, allowing for easy static or dynamic mode configuration.

There are three LEDs to indicate sensor detection status at all times.

Teach-In is also possible via the sensor's pin 5.

MidC/B Series



Through-beam mode operation

Through-beam ultrasonic sensors use dedicated emitter and receiver transducers. They are extremely accurate and detect small and moving objects.

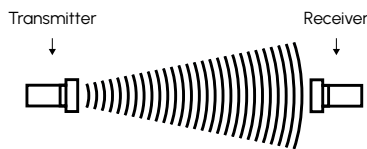

The peculiarity of this arrangement is that there is no blind zone.

Sensors are fitted opposite each other on a common axis. The sensor output switch is activated when the sound wave is interrupted by an object.

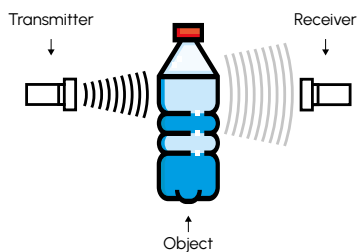

Receiver sensitivity can normally be set for different intervals between the transmitter and receiver and/or for different object sizes.

This operating mode is particularly resistant to external interferences. It also doubles the operating

range and enables reliable object detection and considerably greater distances.

Switching frequency is substantially faster because the sensor does not have to continually change between transmission and reception modes. Accordingly, this option is particularly suited to high-speed uses, such as bottle counting.

Exceptional characteristics

The Midatec ultrasonic through-beam system stands out thanks to two features that account for its efficiency and accuracy:

Filter and Sensitivity.

Sensitivity: The different modes make it possible to adjust the size of the object to be detected.

Filter: Enables adjustment of object detection robustness or stability.

Advantages

- ▶ There is no blind zone.
- ▶ Long range, in other words, you can have large distances between transmitter and receiver.
- ▶ Very high switching frequency.

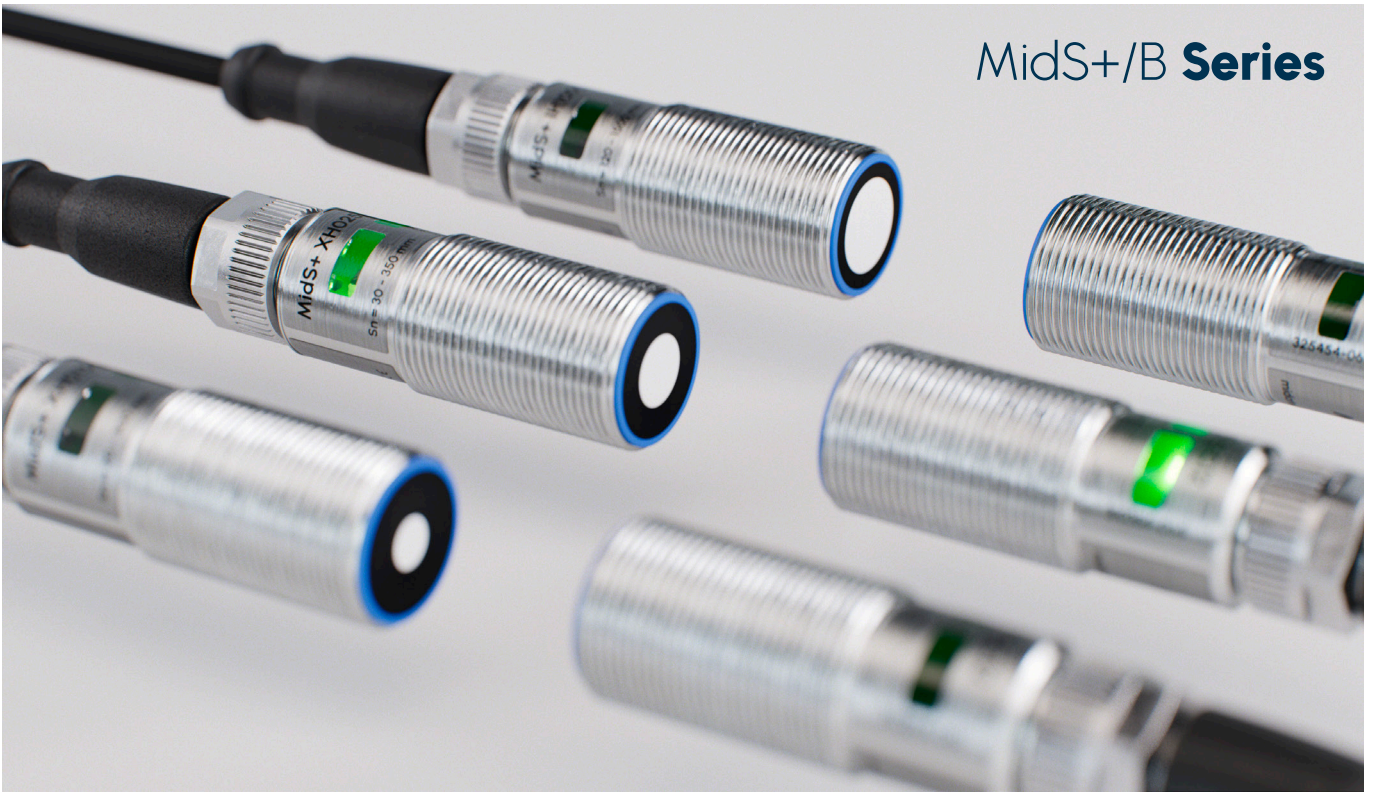

Applications

- ▶ Ideal for detecting transparent objects (e.g., PET bottles at filling and washing feed stations).
- ▶ Ideal for detecting PET bottles on linear conveyor systems.
- ▶ Excellent immunity from compressed air interference.
- ▶ Fast response behaviour to detect minimum empty spaces.
- ▶ Object detection regardless of colour and transmission, including in very wet environments.
- ▶ Detection of the most difficult materials, such as glass or transparent plastic bottles.
- ▶ Optimised for putting into vessels.
- ▶ Stainless steel housing (MidS+).
- ▶ Ideal for high-speed uses.





Reference	MidC XH015C08B	MidC XH070C08B														
Output type	Digital Push-Pull output	Digital Push-Pull output														
Transmitter -receiver distance	0-500 mm	0-1500 mm														
Transducer frequency	380 kHz	300 kHz														
Supply voltage	10-30 Vdc	10-30 Vdc														
Own no load consumption	≤35 mA	≤35 mA														
Reproducibility	±0.15%	±0.15%														
Function indicator	Power: Green LED Output: Red LED	Power: Green LED Output: Red LED														
Adjustment elements	Sensitivity and filter (pin 2 or pushbutton)	Sensitivity and filter (pin 2 or pushbutton)														
Digital output	Push-Pull. I _{max} <200 mA NO/NC Adjustable contact Short-circuit protection	Push-Pull. I _{max} <200 mA NO/NC Adjustable contact Short-circuit protection														
Switching frequency (*)	500 Hz	500 Hz														
Response time (*)	2 ms	2 ms														
Protection rating as per EN 60529	IP67	IP67														
Operating temperature	-25 °C...70 °C	-25 °C...70 °C														
Housing material	ABS	ABS														
Detection face material	Epoxy resin and polyurethane foam	Epoxy resin and polyurethane foam														
Connections	4-pin, M8x1 connector	4-pin, M8x1 connector														
Definition of barrier mode ranges (*) Depends on programming.	<table border="1"> <thead> <tr> <th>Mounting distance</th> <th>Ø Minimum detectable object</th> </tr> </thead> <tbody> <tr> <td>20 mm</td> <td>10 mm</td> </tr> <tr> <td>150 mm</td> <td>10 mm</td> </tr> </tbody> </table>	Mounting distance	Ø Minimum detectable object	20 mm	10 mm	150 mm	10 mm	<table border="1"> <thead> <tr> <th>Mounting distance</th> <th>Ø Minimum detectable object</th> </tr> </thead> <tbody> <tr> <td>100 mm</td> <td>27 mm</td> </tr> <tr> <td>500 mm</td> <td>27 mm</td> </tr> <tr> <td>1500 mm</td> <td>40 mm</td> </tr> </tbody> </table>	Mounting distance	Ø Minimum detectable object	100 mm	27 mm	500 mm	27 mm	1500 mm	40 mm
Mounting distance	Ø Minimum detectable object															
20 mm	10 mm															
150 mm	10 mm															
Mounting distance	Ø Minimum detectable object															
100 mm	27 mm															
500 mm	27 mm															
1500 mm	40 mm															

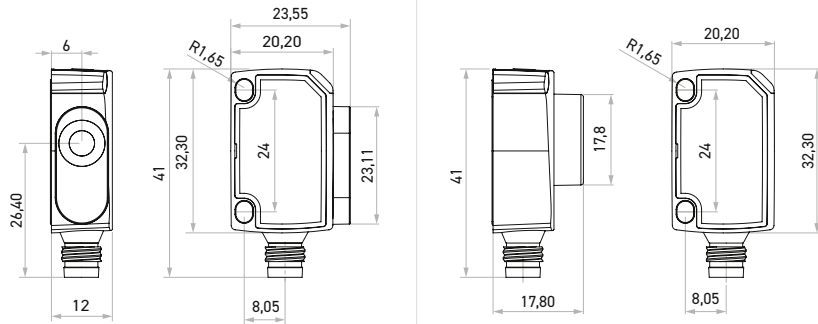

Connection diagram

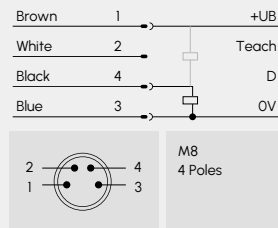



MidS+ XH015C12B		MidS+ XH025C12B		MidS+ XH100C12B	
Digital Push-Pull output		Digital Push-Pull output		Digital Push-Pull output	
0-500 mm		0-700 mm		0-2400 mm	
380 kHz		320 kHz		190 kHz	
10-30 Vdc		10-30 Vdc		10-30 Vdc	
≤40 mA		≤40 mA		≤40 mA	
±0.15%		±0.15%		±0.15%	
Power: Green LED Output: Red LED		Power: Green LED Output: Red LED		Power: Green LED Output: Red LED	
Sensitivity and filter (pin 5)		Sensitivity and filter (pin 5)		Sensitivity and filter (pin 5)	
Push-Pull. I _{max} <200 mA NO/NC Adjustable contact Short-circuit protection		Push-Pull. I _{max} <200 mA NO/NC Adjustable contact Short-circuit protection		Push-Pull. I _{max} <200 mA NO/NC Adjustable contact Short-circuit protection	
500 Hz		500 Hz		200 Hz	
2 ms		2 ms		5 ms	
IP67		IP67		IP67	
-25 °C...70 °C		-25 °C...70 °C		-25 °C...70 °C	
Stainless Steel and PBT		Stainless Steel and PBT		Stainless Steel and PBT	
Epoxy resin and polyurethane foam		Epoxy resin and polyurethane foam		Epoxy resin and polyurethane foam	
5-pin, M12x1 connector		5-pin, M12x1 connector		5-pin, M12x1 connector	
Mounting distance	Ø Minimum detectable object	Mounting distance	Ø Minimum detectable object	Mounting distance	Ø Minimum detectable object
50 mm	10 mm	100 mm	27 mm	625 mm	70 mm
150 mm	10 mm	200 mm	27 mm	1250 mm	70 mm
		400 mm	40 mm	2500 mm	70 mm

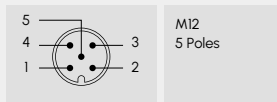
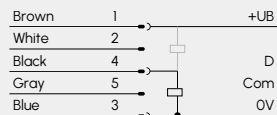
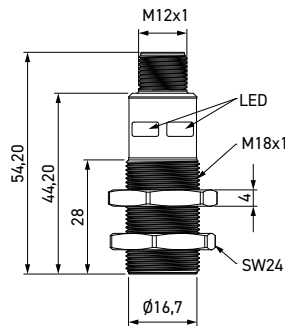

TLK Case

Programming and adjustment kit



TLK device

Characteristics

- ▶ Size: 73x117x24mm
- ▶ PMMA housing
- ▶ 128 x 64 Graphic LCD, white backlight
- ▶ 4-pin male, M12x1 transformer connector
- ▶ 5-pin female, M12x1 sensor connector
- ▶ Interface in different languages

Protections

- ▶ IP54
- ▶ Short-circuit
- ▶ Overload
- ▶ Reverse polarity

Kit content

TLKUSB02 - CASE

- ▶ Transformer
- ▶ 220 Vac/24 Vdc transformer with 4-pin female, M12x1 connector
- ▶ USB extension
- ▶ A Male-USB extension (Connect to PC)
- ▶ B Male-USB (Connect to the TLKUSB02 device)
- ▶ TLKUSB02 device
- ▶ 2x16 LCD Display, 3x5.23 mm char. black background and blue letters
- ▶ USB with MIDConnect software
- ▶ TLK controller software



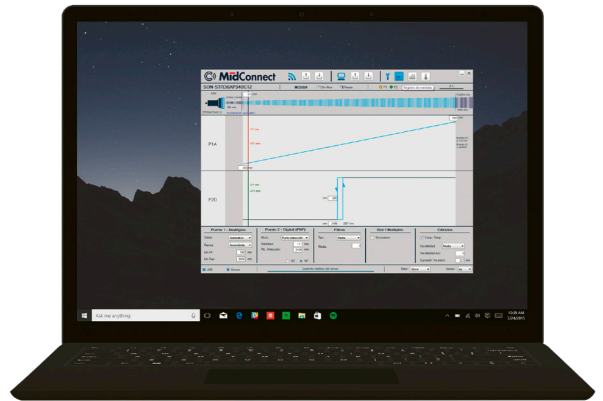

MidConnect is in-house software to fully leverage sensor possibilities

- ▶ Sensor control
- ▶ Type, data and measurements
- ▶ Identification of available ports
- ▶ Synchronisation / Multiplexing for the number of sensors used
- ▶ Advanced settings:
 - ▶ Temperature offset
 - ▶ Sensitivity
 - ▶ Echo attenuation
 - ▶ Blind zone adjustments

MIDConnect allows for the easy, intuitive and complete configuring and control of programmable Midatec sensor family measurements

- ▶ Work control
- ▶ Read and change sensor configuration
- ▶ Read and save configurations in the sensor to use them again
- ▶ Store configurations on your PC from the connected sensor
- ▶ Tools
- ▶ Measurement record
- ▶ Ex-factory setting restoration
- ▶ Calibrating of temperature offset

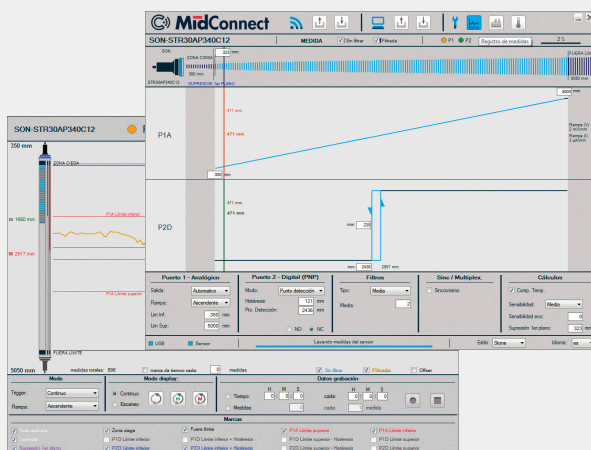

System requirements

Operating System	Windows XP, Vista, Windows 7, Windows 8, Windows 10
Monitor and graphics card	Minimum resolution: 1024x768
	USB 2.0 slot or later to connect the TLKUSB programmer
	Framework .NET 4.5 (installed together with MIDConnect)

INDUCTIVE SENSORS



M8



M12



M18



M30

Technology

Industrial inductive sensors are devices used to detect the presence or absence of metal objects in industrial applications. They work by generating a high frequency magnetic field when a metal object enters its detection range. This produces a variation in the frequency of the magnetic field, which is in turn detected by the sensor and used to activate an output signal.

Main advantages

Inductive sensors are very popular in industry due to their reliability and capacity to operate in harsh environments, such as high temperature ones and humid and dusty surroundings. They are ideal when accurate, repeatable metal object detection is required.

Detecting metal parts on assembly lines, detecting the position of tools in machine tools, detecting objects on conveyor belts and detecting objects in industrial safety equipment are just a few examples of their applications.

Applications

Because of their capacity to detect metal objects with great accuracy in harsh environments, inductive sensors serve a wide range of industrial uses. The following are some of the most common:

Position detection: Inductive sensors are used to detect where parts are positioned on production lines, in machine tools and automation equipment. They are also used in safety applications to detect the presence of objects in hazardous areas.

Process control: Inductive sensors are used to control the flow of materials and products in industrial processes such as making food and drinks, manufacturing chemical products and making pharmaceutical products.

Quality control: Inductive sensors are used for quality control purposes to detect the defects in metal products, such as cracks, pinholes and other surface defects.

Tool position detection: Inductive sensors are used to detect the position of tools in machine tools, such as lathes and milling machines, to ensure accurate placement and avoid collisions.

Object detection on conveyor belts: Inductive sensors are used to detect metal objects on conveyor belts and stop the production line in case of obstruction or when a safety problem arises.

Restricted area object presence detection: Inductive sensors are used for safety purposes to detect the presence of objects in restricted areas, such as in the environs of a dangerous machine or in flammable material storage areas.

Inductive sensors are put to a wide range of uses in industry, ranging from process control to object detection in hazardous areas. Due to their high precision and capacity to operate in harsh environments, they have become a popular and effective solution for many industrial uses.



Basic Series

Inductive proximity sensors





Designed to operate in all types of environmental conditions they come with excellent IP67 protection rating.





From M8 to M30 with a variety of ranges and connection options, the Standard Series covers a broad selection of products and a wide range of uses: Food and drink, packaging, machine tool and car industries, among others.

Mounting options: Flush and Non-flush

Make the most of the different configurations to meet installation requirements. Reduce the impact of surrounding metals and mutual interference when installation several sensors.

General characteristics

	Protection rating	IP67
	Housing material	Nickel-plated brass
	Detection face material	PBT

	Function indicator	Amber LED
	Supply voltage	10- 30 Vdc
	Temperature range	-25 ... +70 °C
	Hysteresis	< 20%



Detection distance

Standard and augmented detection distance versions



Connections

Connections via cable or connector: jack or thermowelded

PVC connection cables

See the accessories section for information about the connectors available.

Housing size

Housing model standard and short

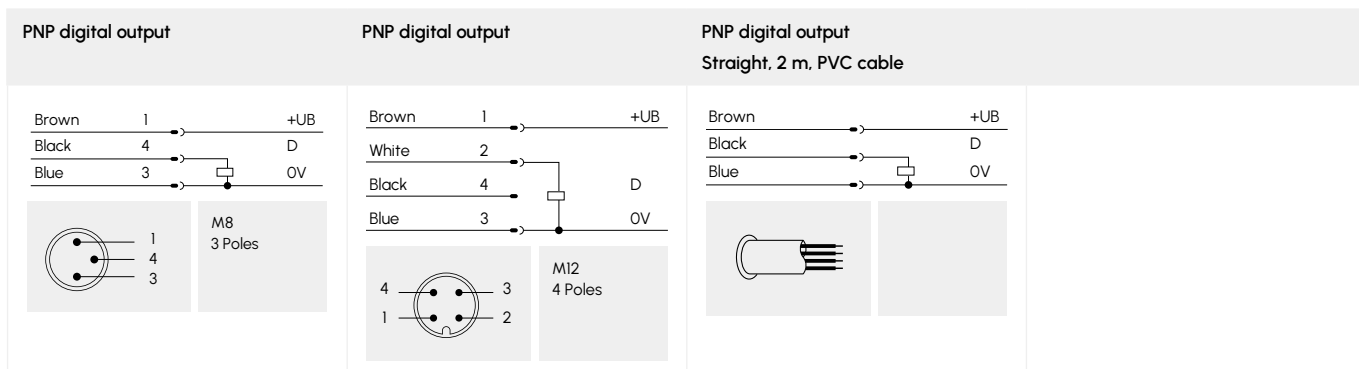

Reference	Sn Range	Housing length	Mounting	Output	Connections
DTS C 08E 02 PA C08	2.0 mm	Short	Flush	PNP; NO	3-pin, M8 connector
DTS C 08E 02 PA K02	2.0 mm	Short	Flush	PNP; NO	Straight cable
DTS C 08E 02 PC C08	2.0 mm	Short	Flush	PNP; NC	3-pin, M8 connector
DTS C 08E 1.5 PA C08	1.5 mm	Short	Flush	PNP; NO	3-pin, M8 connector
DTS C 08E 1.5 PA K02	1.5 mm	Short	Flush	PNP; NO	Straight cable
DTS C 08N 04 PA C08	4.0 mm	Short	Non-flush	PNP; NO	3-pin, M8 connector
DTS C 08N 04 PA K02	4.0 mm	Short	Non-flush	PNP; NO	Straight cable
DTS C 08N 2.5 PA C08	2.5 mm	Short	Non-flush	PNP; NO	3-pin, M8 connector
DTS C 08N 2.5 PA K02	2.5 mm	Short	Non-flush	PNP; NO	Straight cable
DTS S 08E 02 PA C08	2.0 mm	Standard	Flush	PNP; NO	3-pin, M8 connector
DTS S 08E 02 PA K02	2.0 mm	Standard	Flush	PNP; NO	Straight cable
DTS S 08E 1.5 PA C08	1.5 mm	Standard	Flush	PNP; NO	3-pin, M8 connector
DTS S 08E 1.5 PA K02	1.5 mm	Standard	Flush	PNP; NO	Straight cable
DTS S 08N 04 PA C08	4.0 mm	Standard	Non-flush	PNP; NO	3-pin, M8 connector
DTS S 08N 04 PA K02	4.0 mm	Standard	Non-flush	PNP; NO	Straight cable
DTS S 08N 2.5 PA C08	2.5 mm	Standard	Non-flush	PNP; NO	3-pin, M8 connector
DTS S 08N 2.5 PA K02	2.5 mm	Standard	Non-flush	PNP; NO	Straight cable

Figures

Flush; Short; M8 Connector

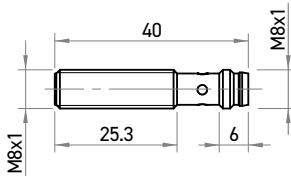

Flush; Short; Cable

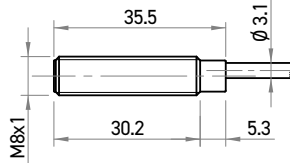

Flush; Standard; M8 Connector

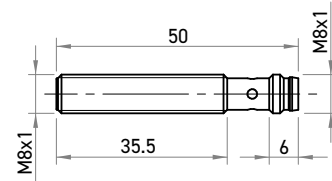

Flush; Standard; Cable

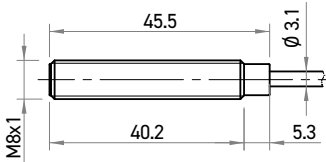

Non-flush; Short; M8 Connector

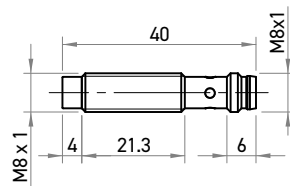

Non-flush; Short; Cable

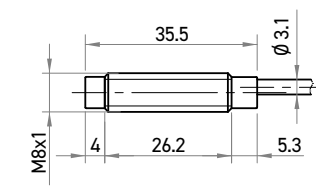

Non-flush; Standard; M8 Connector

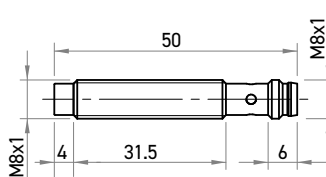

Non-flush; Standard; Cable

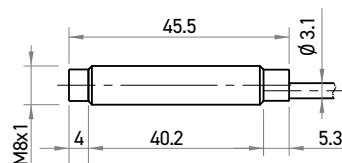

M12

Reference	Sn Range	Housing length	Mounting	Output	Connections
DTS C I2E 02 PA C12	2.0 mm	Short	Flush	PNP; NO	5-pin 4 wire M12 connector
DTS C I2E 02 PA K02	2.0 mm	Short	Flush	PNP; NO	Straight cable
DTS C I2E 02 PC C12	2.0 mm	Short	Flush	PNP; NC	5-pin 4 wire M12 connector
DTS C I2E 04 PA C12	4.0 mm	Short	Flush	PNP; NO	5-pin 4 wire M12 connector
DTS C I2E 04 PA K02	4.0 mm	Short	Flush	PNP; NO	Straight cable
DTS C I2N 04 PA C12	4.0 mm	Short	Non-flush	PNP; NO	5-pin 4 wire M12 connector
DTS C I2N 04 PA K02	4.0 mm	Short	Non-flush	PNP; NO	Straight cable
DTS C I2N 08 PA C12	8.0 mm	Short	Non-flush	PNP; NO	5-pin 4 wire M12 connector
DTS C I2N 08 PA K02	8.0 mm	Short	Non-flush	PNP; NO	Straight cable
DTS S I2E 02 PA C12	2.0 mm	Standard	Flush	PNP; NO	5-pin 4 wire M12 connector
DTS S I2E 02 PA K02	2.0 mm	Standard	Flush	PNP; NO	Straight cable
DTS S I2E 04 NA C12	4.0 mm	Standard	Flush	NPN; NO	5-pin 4 wire M12 connector
DTS S I2E 04 PA C12	4.0 mm	Standard	Flush	PNP; NO	5-pin 4 wire M12 connector
DTS S I2E 04 PA K02	4.0 mm	Standard	Flush	PNP; NO	Straight cable
DTS S I2N 04 PA C12	4.0 mm	Standard	Non-flush	PNP; NO	5-pin 4 wire M12 connector
DTS S I2N 04 PA K02	4.0 mm	Standard	Non-flush	PNP; NO	Straight cable
DTS S I2N 08 PA C12	8.0 mm	Standard	Non-flush	PNP; NO	5-pin 4 wire M12 connector
DTS S I2N 08 PA K02	8.0 mm	Standard	Non-flush	PNP; NO	Straight cable

Figures

Flush; Short; M12 Connector

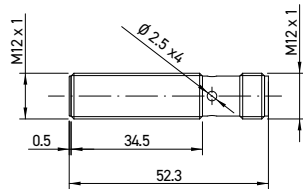

Flush; Short; Cable

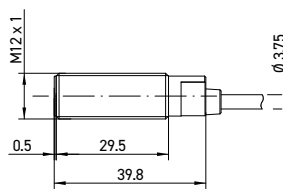

Flush; Standard; M12 Connector

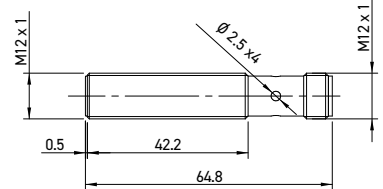

Flush; Standard; Cable

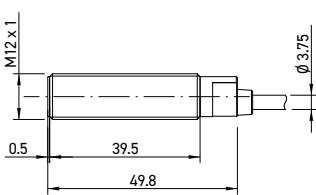

Non-flush; Short; M12 Connector

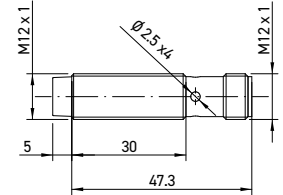

Non-flush; Short; Cable

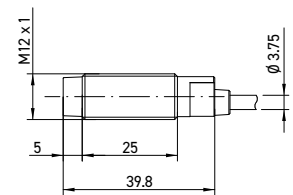

Non-flush; Standard; M12 Connector

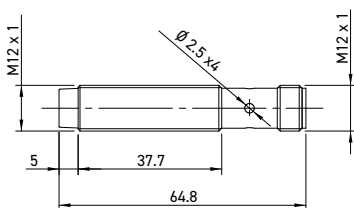

Non-flush; Standard; Cable

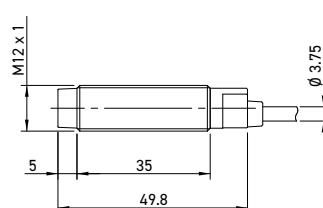

M18

Reference	Sn Range	Housing length	Mounting	Output	Connections
DTS C 18E 05 PA C12	5.0 mm	Short	Flush	PNP; NO	5-pin 4 wire M12 connector
DTS C 18E 05 PA K02	5.0 mm	Short	Flush	PNP; NO	Straight cable
DTS C 18E 08 PA C12	8.0 mm	Short	Flush	PNP; NO	5-pin 4 wire M12 connector
DTS C 18E 08 PA K02	8.0 mm	Short	Flush	PNP; NO	Straight cable
DTS C 18N 08 PA C12	8.0 mm	Short	Non-flush	PNP; NO	5-pin 4 wire M12 connector
DTS C 18N 08 PA K02	8.0 mm	Short	Non-flush	PNP; NO	Straight cable
DTS C 18N 12 PA C12	12.0 mm	Short	Non-flush	PNP; NO	5-pin 4 wire M12 connector
DTS C 18N 12 PA K02	12.0 mm	Short	Non-flush	PNP; NO	Straight cable
DTS S 18E 05 PA C12	5.0 mm	Standard	Flush	PNP; NO	5-pin 4 wire M12 connector
DTS S 18E 05 PA K02	5.0 mm	Standard	Flush	PNP; NO	Straight cable
DTS S 18E 08 PA C12	8.0 mm	Standard	Flush	PNP; NO	5-pin 4 wire M12 connector
DTS S 18E 08 PA K02	8.0 mm	Standard	Flush	PNP; NO	Straight cable
DTS S 18E 08 PS C12	8.0 mm	Standard	Flush	PNP; NO	5-pin 4 wire M12 connector
DTS S 18N 08 PA C12	8.0 mm	Standard	Non-flush	PNP; NO	5-pin 4 wire M12 connector
DTS S 18N 08 PA K02	8.0 mm	Standard	Non-flush	PNP; NO	Straight cable
DTS S 18N 12 PA C12	12.0 mm	Standard	Non-flush	PNP; NO	5-pin 4 wire M12 connector
DTS S 18N 12 PA K02	12.0 mm	Standard	Non-flush	PNP; NO	Straight cable

Figures

Flush; Short; M12 Connector

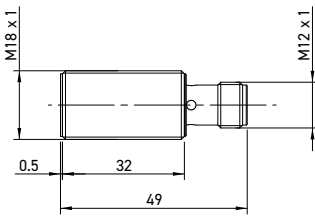

Flush; Short; Cable

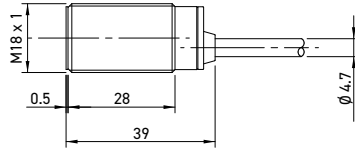

Flush; Standard; M12 Connector

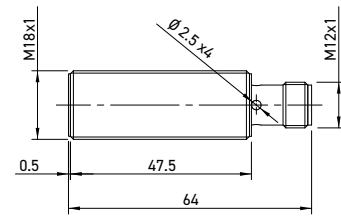

Flush; Standard; Cable

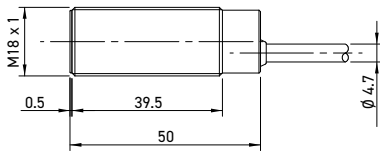

Non-flush; Short; M12 Connector

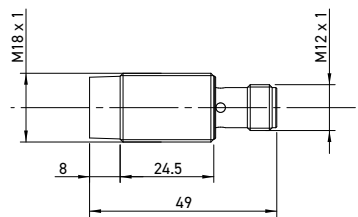

Non-flush; Short; Cable

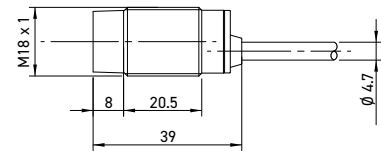

Non-flush; Standard; M12 Connector

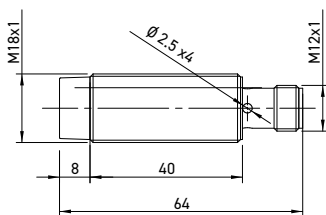

Non-flush; Standard; Cable

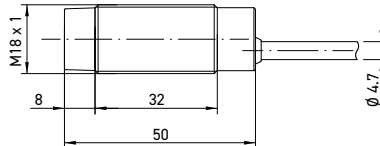

M30

Reference	Sn Range	Housing length	Mounting	Output	Connections
DTS C 30E 15 PA C12	15.0 mm	Short	Flush	PNP; NO	5-pin 4 wire M12 connector
DTS S 30E 10 PA C12	10.0 mm	Standard	Flush	PNP; NO	5-pin 4 wire M12 connector
DTS S 30E 10 PA K02	10.0 mm	Standard	Flush	PNP; NO	Straight cable
DTS S 30E 15 PA C12	15.0 mm	Standard	Flush	PNP; NO	5-pin 4 wire M12 connector
DTS S 30E 15 PA K02	15.0 mm	Standard	Flush	PNP; NO	Straight cable
DTS S 30N 15 PA C12	15.0 mm	Standard	Non-flush	PNP; NO	5-pin 4 wire M12 connector
DTS S 30N 15 PA K02	15.0 mm	Standard	Non-flush	PNP; NO	Straight cable
DTS S 30N 20 PA C12	20.0 mm	Standard	Non-flush	PNP; NO	5-pin 4 wire M12 connector
DTS S 30N 20 PA K02	20.0 mm	Standard	Non-flush	PNP; NO	Straight cable

Figures

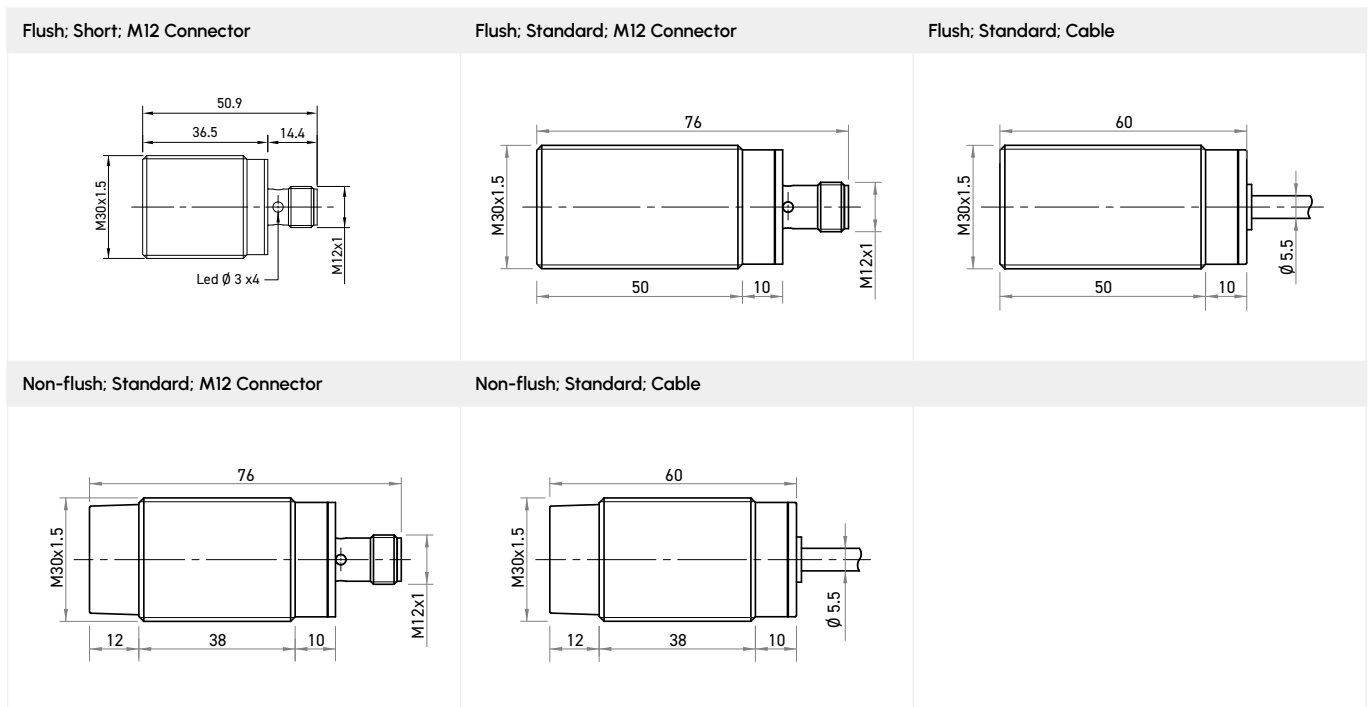

Technology

Main advantages

Photoelectric sensors use light to detect the presence or absence of objects, as well as to measure distance, speed, position and other parameters. These sensors comprise a light emitter+ (like an LED) and a light receiver (like a phototransistor) which work together to detect the presence or absence of an object.

There are several types of photoelectric sensors, such as through-beam, reflective, diffuse-reflection and polarised ones. Through-beam sensors emit a light beam and detect an object when the light beam is blocked. Reflective sensors emit a beam of light that

is reflected by the object to a receiver. Diffuse-reflection sensors emit a beam of light that is reflected by the object in all directions and later detected by a receiver. Polarised sensors polarise light to detect the presence of an object.

Photoelectric sensors have a wide variety of uses, such as, among others, in industry to detect production line objects, in smart buildings to detect the presence of people in a room or in robotics to detect obstacles.

Contactless detection

Contactless detection avoids damage to both objects and sensors, thus guaranteeing a long service life and maintenance-free functioning.

High-speed response

High-speed detection of objects.

Detection of a wide range of materials

As detection is based on reflection or on the amount of light interrupted, practically all materials can be detected, such as, among others, glass, metals, plastic, wood and liquids.

Magnetic fields have little impact

Objects are detected using light.

Operating principles

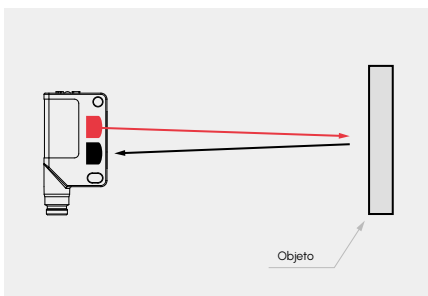

Direct reflection

In direct reflection or direct energy reflection mode, the sensor has an emitter and receiver in the same housing, which makes this a versatile and cost-effective solution. Easy to install, no reflector is required.

The operating principle consists of the emitter issuing a beam of light towards an object, which acts as a reflector, thereby returning the light emitted to the receiver that captures this amount of reflected light. The sensor is triggered when the intensity of the light reaches the threshold value.

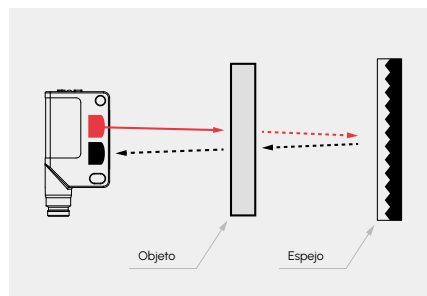

Mirror reflection

As is the case with direct reflection, the sensor has a transmitter and receiver in the same housing, but in this case the operating principle makes use of a high-performance, fixed reflector that ensures the return of the light beam. When the object blocks the said light beam, the intensity of the light received drops and the sensor is activated. The relative high level of light reflected enables the sensor to reach longer distances.

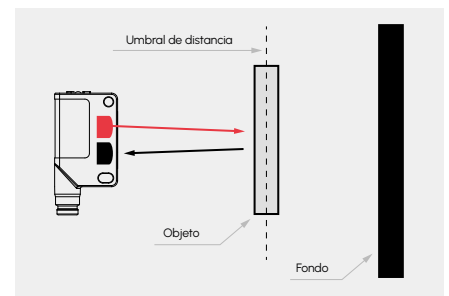

Direct reflection using background suppression

The sensor no longer depends of the intensity of the light beam, but on the angle of the light reflected. Accordingly, the operating distance does not depend on the surface condition or colour of the object.

This operating principle means that detection is not greatly affected by the colour, brightness, size or shape of the object to be detected.

OM/18 Series



M18 barrel housing

Provides a high level of detection accuracy and reliable performance in industrial and highly demanding environments.

M18 red light photoelectric barrel sensors are devices that are used to detect objects by emitting light and measuring its reflection.

Photoelectric sensors are widely used in automated industrial settings to detect objects on production lines, in packaging and in stock control, as well as for other purposes that require accurate and reliable detection. Red light is one of the most popular options

IP67 protection rating

Shock and vibration resistant owing to the complete encapsulation of the electronics

4 mode **programmable response** time: 100 us, 300 us, 1 ms, 2 ms

for photoelectric sensors on account of its high visibility and contrast properties.

M18 red light barrel sensors are compact and easy to install, which makes them ideal for a wide range of industrial uses. Moreover, these durable sensors resist harsh environmental conditions like humidity, dust and vibration, which makes them the reliable choice for demanding industrial settings.

Technical specifications

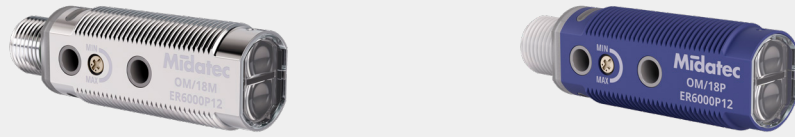

	OM/18M		OM/18P	
	OM/18M ER6000P12	OM/18M RI400P12	OM/18P ER6000P12	OM/18P RI400P12
Connection description	5-pin 4 wire M12 connector			
Operating principle	Mirror reflection	Direct power reflection	Mirror reflection	Direct power reflection
Operating range	6000 mm	400 mm	6000 mm	400 mm
Standard reference lens	100 x 100 mm catadioptric	200 x 200 mm White Kodak paper	100 x 100 mm catadioptric	200 x 200 mm White Kodak paper
Light source	LED			
Colour	Red	Infrared	Red	Infrared
Polarised light	Yes	No	Yes	No
Wave length	660 nm	880 nm	660 nm	880 nm
External light immunity	3 kLux Halogen Light 10 kLux Sunlight			
Input voltage UB	10 ... 30 Vdc			
Reverse polarity protection	Yes			
Own no load consumption	≤30 mA			
Function indicator	Power: Green LED ON light: Amber LED			
Sensitivity adjustment	Potentiometer			
Outputs	PNP; Ub-2 V, I max = 100 mA NO/NC pin adjustable			
Digital output protection	Short-circuit protection			
Switching frequency	1000 Hz			
Response time	≤0.5 mS			
Protection rating	IP67			
Operating temperature	-25 ...+55 °C			
Threaded bushing	M18			
Housing material	Nickel-plated brass		ABS	
Detection face material	PMMA			

Dimensions

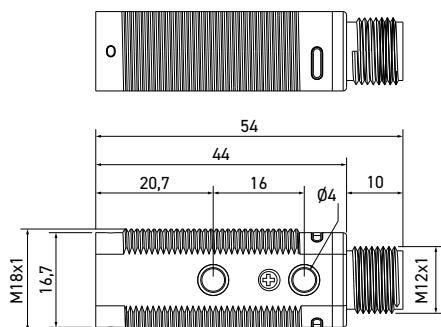

Connection diagram

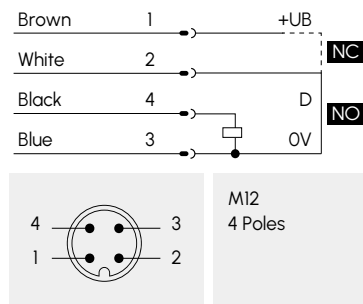

OM/32 Series



Extremely compact, rectangular housing

These sensors are very useful when quick and accurate light presence detection is required. Their compactness make them ideal for use in systems where space is limited.

IP67 protection rating

4-pin, M8 connector

Potentiometer adjusted sensitivity

Switch adjustable NO/NC

LED function indicator



Some of the features provided by a compact, square housing, photoelectric sensor are the capacity to adjust sensor sensitivity; the possibility of using different light wavelengths to adapt to different materials; and the capacity to integrate the sensor into other automated control systems.

Technical specifications



	OM/32 OI1000P08	OM/32 ER5000P08	OM/32 SI400P08	OM/32 RR1000P08
Connection description	4-pin, M8 connector			
Operating principle	Transparent object	Mirror reflection	D.R. background suppression	Direct power reflection
Minimum work distance	50 mm	20 mm	30 mm	-
Operating range	1000 mm	5000 mm	400 mm	1000 mm
Availability delay	≤100 ms			
Light source	LED			
Colour	Infrared	Red	Infrared	Red
Polarised light	No	Yes	No	No
Wave length	850 nm	630 nm	850 nm	660 nm
External light immunity	3 kLux Halogen Light 10 kLux Sunlight			
Input voltage UB	10 ... 30 Vdc			
Reverse polarity protection	Yes			
Own no load consumption	≤45 mA	≤30 mA	≤45 mA	≤30 mA
Reproducibility	5%			
Temperature offset	Yes, ≤10% drift			
Function indicator	ON light: Amber LED	Excess Gain: Green LED ON light: Amber LED	ON light: Amber LED	Excess Gain: Green LED ON light: Amber LED
Sensitivity adjustment	Potentiometer			
Outputs	PNP; Ub-2 V, I max = 100 mA Adjustable NO/NC pin			
Digital output protection	Short-circuit protection			
Hysteresis	≤10%			
Switching frequency	2000 Hz		1000 Hz	
Response time	≤0.25 ms			
Protection rating	IP67			
Operating temperature	-25 ...70 °C			
Housing material	Plastic (PA 66)			
Detection face material	PMMA			

Dimensions

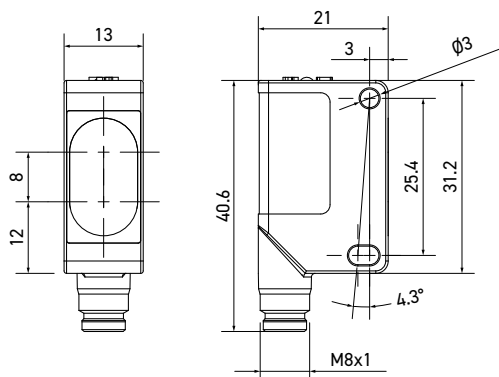

Connection diagram

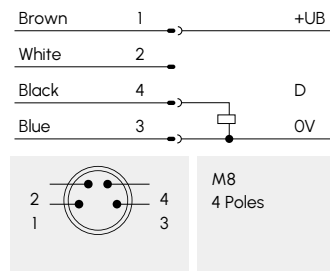

OM/DIN Series

Fibre-optic amplifier



Robust, durable and customisable length
diffuse-reflection or **barrier** sensors.

Intuitive handling and high performance to ensure maximum and efficient control.

One of the advantages of these types of sensors is that the fibre optic amplifiers can be very long range and can target places that are difficult to access, thus providing enhanced flexibility of use. Moreover, they are extremely accurate and provide high-speed detection response for very small objects.

Mounted on DIN rail (DIN/EN 50022)

IP64 protection rating

4 mode **programmable response** time: 100 us, 300 us, 1 ms, 2 ms

Fibre optic sensors are used for a variety of purposes, such as: detecting moving objects; measuring liquid levels in tanks; presence detecting on production lines; and measuring temperature and pressure in harsh environments.

This type of sensor is widely used in industry and in automation processes, owing to its capacity to detect the presence or absence of light in places that are difficult to access or where environmental conditions are particularly harsh. Moreover, fibre optic sensors are immune to electromagnetic interference, which makes them very useful in industrial environments with high electrical noise levels.





PMMA plastic fibre optics.

These fibres are flexible and light, not to mention cost-effective, which explains why they are the most common type of fibre optic sensor.

Installation ready with five present scanning ranges

No operational elements, manipulation proof

Stainless steel housing, ideal for strict hygiene and cleanliness requirements

	OM/DIN ARP08/3 001
Operating principle	Amplifier
Operating range	Direct reflection: 200 mm. Barrier: 1200 mm
Standard reference lens	Ø1 mm fibre core
Light source	LED
Colour	Red
Polarised light	No
Wave length	660 nm
Response time	Programmable (4 modes): 100 us, 300 us, 1 ms, 2 ms
Input voltage (UB)	12 ... 24 Vdc ±10%
Reverse polarity protection	Yes
Own no load consumption	<40 mA
Function indicator	Red LED
Sensitivity adjustment	2x, 4-digit Display and Pushbuttons
Connection type	Connector
Connector	M8
Pins	3
Wires	3
Gender	Male
Outputs	PNP: UB -2 V, 1 mA _x = 100 mA NO/NC adjustable contact
Digital output protection	Short-circuit protection
Protection rating IEC 60529 International Standard	IP64
Operating temperature	-10 ...+50 °C
Housing material	ABS+PC



Dimensions

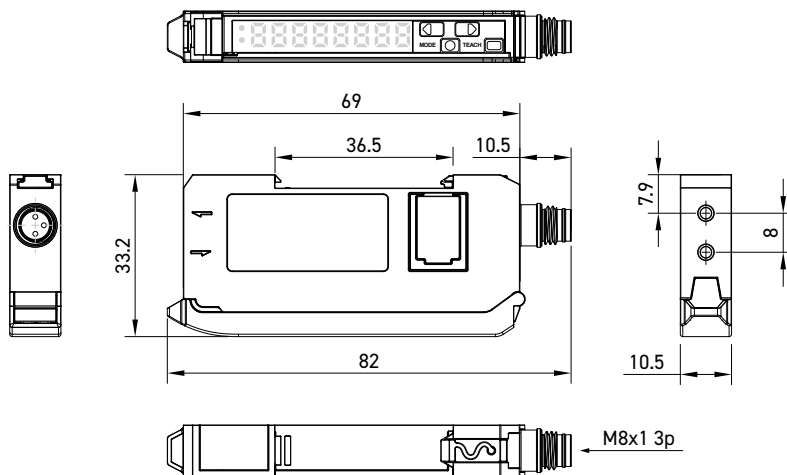



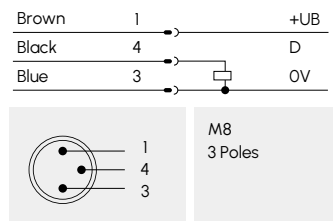

Connection diagram

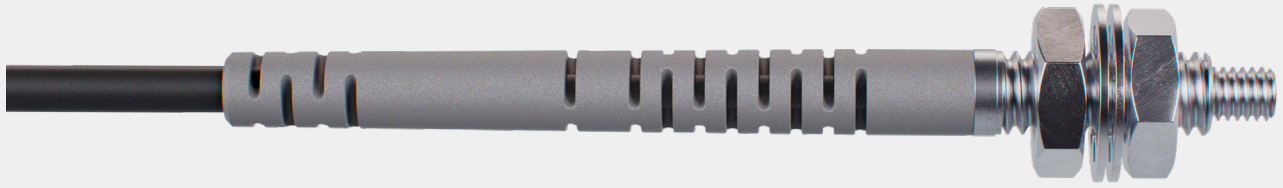

Fibre optics

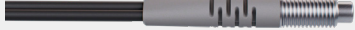

Accessories included: Nuts and washers (2x)

	Reference	Operating principle	Fibre Material	Head size	Operating range	Min. bend radius	Light angle
	FOB/SB 420S	Barrier	PMMA	M4x0.7 mm	1000 mm	R25	60°
	FOB/SB 620P	Barrier	PMMA	M6x0.75 mm	1000 mm	R15	12°
	FOB/SR 320C	Reflection	PMMA	M3x0.5mm	30 mm	R15	60°
	FOB/SR 420C	Reflection	PMMA	M4x0.7 mm	60 mm	R15	60°
	FOB/SR 620C	Reflection	PMMA	M6x0.75 mm	140 mm	R25	60°

Accessories

Cutting accessory

AD017

Cutting accessory for synthetic fibre optic

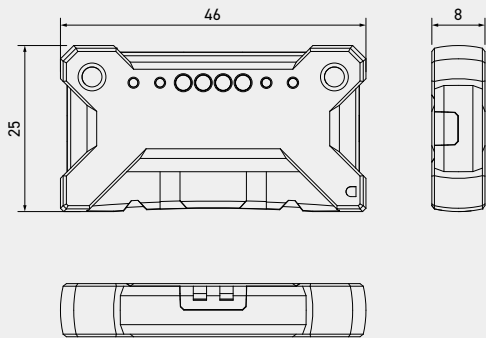
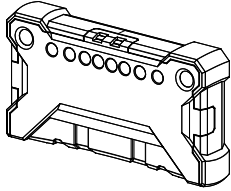

Fibre-optic adapter

AD018

Ø1.4 mm synthetic fibre-optic adapter

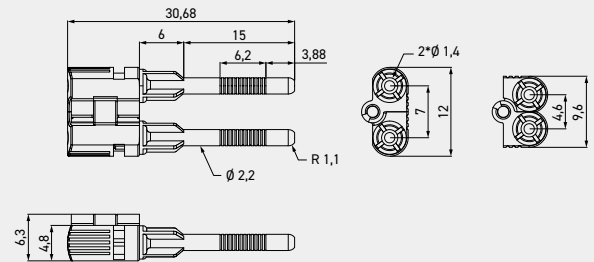
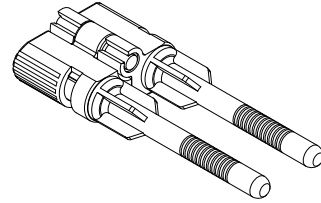

Reflectors

AD012

Ø46 mm mirror

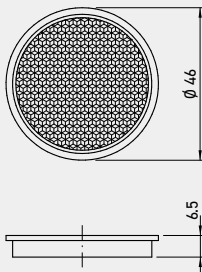

AD013

Ø84 mm mirror

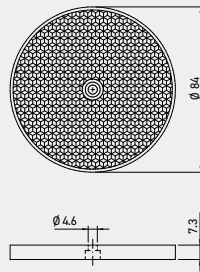

AD014

100x100 mm adhesive mirror

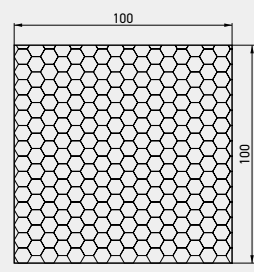

OM/FR Series

Fork Through-Beam Sensors

Unrivalled accuracy in detecting small parts.



Fork, red light, through-beam photoelectric sensors are used to detect objects and material on production lines and in automated systems.

Specifically, infrared is a wavelength widely used in these sensors owing to its high sensitivity and capacity to penetrate transparent objects.

These sensors comprise two main components: the

emitter and receiver. The emitter is a red light source that transmits a light beam through a fork or slot. The receiver, which is located on the opposing side of the fork, detects the light that passes through the slot, using it to determine object presence, or absence. When an object blocks the light beam, the receiver does not receive a signal, thus activating an electric signal output that can be used to control other devices.

Applications



These sensors can be used for a variety of purposes, including: detecting parts on a production line; supervising the position of objects on a conveyor belt; and detecting obstructions in an automated system.

Moreover, on account of using red light they are less susceptible to environmental interference than sensors that use visible or infrared light.

A typical through-beam arrangement has a red light emitter transmitting a beam towards a receiver positioned opposite it. When an object obstructs the light, less light is picked up at the receiver, which activates the sensor and indicates the presence of the object.

Due to their high precision, speed and accuracy, these sensors are valuable tools when it comes to automating industrial processes.

IP67 protection rating

Robust, resistant metal housing with integrated electronics

Highly immune to ambient lighting owing to emitter and receiver modulation

High switching frequency

Quick and easy installation



3-pin, M8 connector with LED status indicator

Accessible, user friendly adjustments using a potentiometer

NO/NC switching

Sensitivity

Robust, space-saving design, offering simplicity and versatility



Technical specifications

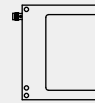

	OM/FR 030 POC C8	OM/FR 050 POC C8	OM/FR 080 POC C8	OM/FR 120 POC C8
Fork width	30 mm	50 mm	80 mm	120 mm
Fork depth	35 mm	55 mm	55 mm	60 mm
Light source	LED	LED	LED	LED
Colour	Red	Red	Red	Red
Resolution	0.4 mm	0.4 mm	0.4 mm	0.4 mm
Sensitivity adjustment	Potentiometer	Potentiometer	Potentiometer	Potentiometer
Own no load consumption	<35 mA	<35 mA	<35 mA	<35 mA
Hysteresis	< 0.2 mm	< 0.2 mm	< 0.2 mm	< 0.2 mm
Reproducibility	< 0.01 mm	< 0.01 mm	< 0.01 mm	< 0.01 mm
Input voltage (UB)	10 - 35 Vdc	10 - 35 Vdc	10 - 35 Vdc	10 - 35 Vdc
Temperature drift	< 10%	< 10%	< 10%	< 10%
Operating temperature	- 10 °C ... + 60 °C	- 10 °C ... + 60 °C	- 10 °C ... + 60 °C	- 10 °C ... + 60 °C
Protection rating IEC 60529 International Standard	IP67	IP67	IP67	IP67
External light immunity	50 klx	50 klx	50 klx	50 klx
Max. isolation voltage	500 V	500 V	500 V	500 V
Max. load current	200 mA	200 mA	200 mA	200 mA
Max. voltage dip	< 2.5 V	< 2.5 V	< 2.5 V	< 2.5 V
Switching type	PNP	PNP	PNP	PNP
Contact	NO/NC	NO/NC	NO/NC	NO/NC
Digital output protection	Short-circuit protection	Short-circuit protection	Short-circuit protection	Short-circuit protection
Switching frequency	2.5 kHz	2.5 kHz	2.5 kHz	2.5 kHz
Protection class	Class III safety for low voltage	Class III safety for low voltage	Class III safety for low voltage	Class III safety for low voltage
Connections	Connector	Connector	Connector	Connector
Connector	M8	M8	M8	M8
Pins	3	3	3	3
Wires	3	3	3	3
Dimensions (mm)	70x50x10	90x70x10	90x100x10	100x144x12
Weight (g)	50	50	80	150
Housing material	Black anodised aluminium	Black anodised aluminium	Black anodised aluminium	Black anodised aluminium



Figures

Connections

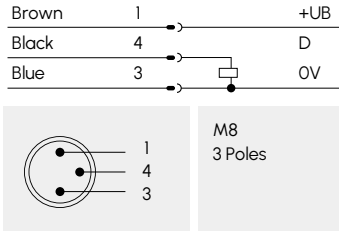

OM/FR 030

OM/FR 050

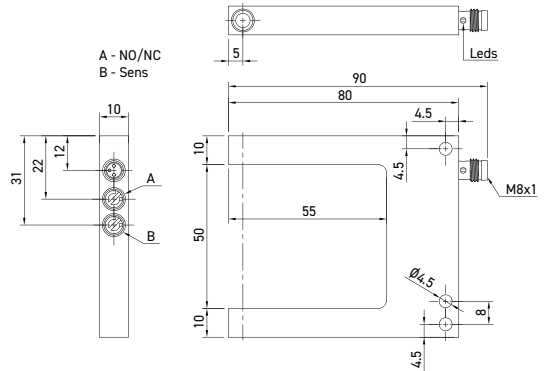
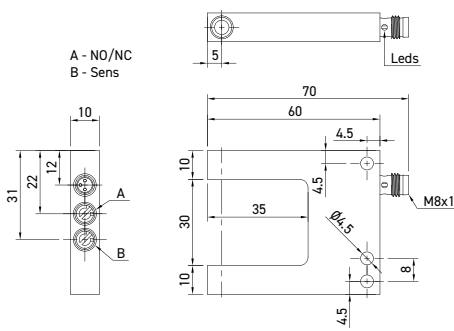

OM/FR 080

OM/FR 120

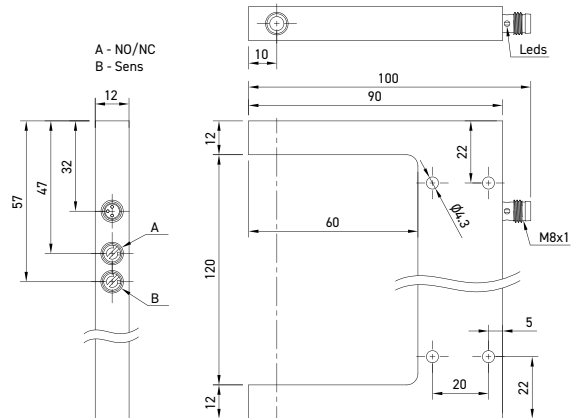
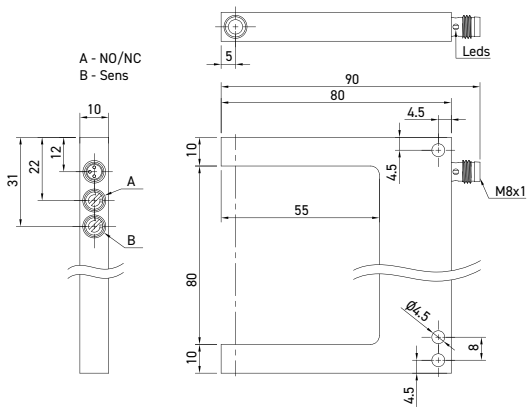

INDUSTRIAL SAFETY

SECURE CONTROL OF SAFETY DOORS AND POSITION FOR ANY ENVIRONMENT OR USE.

Our safety switches help prevent access to potentially hazardous areas unless they are safe.



DMS Series
Slimline safety switches



DMS/S Series
Compact safety switches



DMS/5 Series
Safety switches



DMS/M Series
Door protection with locking



DMS/M1 Series
Door protection with locking



RSM 003E1
Safety relay

Designed to work in harsh environments, our contactless safety switches offer a very long service life and better vibration and shock resistance than conventional electro-mechanical switches.

Maximum certification, guarantee and safety

Our switches enable the obtention of the highest PLe and SIL3 circuit safety level certification by fitting a single protection device.

Product safety, functional safety



All of our safety series products are designed and manufactured to TÜV certification standard, meeting all functional and product aspects, while also complying with environmental and electrical requirements.

Operating principles

Magnetic

- ▶ Coded to avoid manipulation.
- ▶ Increases response time in comparison to RFID technology.

RFID

- ▶ With over 4 billion codes, RFID technology offers a highly secure system against manipulation.
- ▶ Longer detection distance.
- ▶ RFID is more immune to noise.

We have versions with inputs that make possible the serial connection of switches and ones without inputs, to be connected only individually.

Industrial safety switches

Industrial safety switches are devices that are used to protect workers and machines in industrial environments. These switches are needed to prevent people getting hurt and machinery being damaged, which can happen due to faulty operation, lack of maintenance or equipment failure.

Industrial safety switches come in several types, but can generally be divided into two categories: interlock switches and emergency stop ones.

Interlock switches are devices used to avoid a machine being activated unwittingly. These switches work by means of a locking mechanism that prevents machine activation unless certain safety conditions are met. For example, a machine can be fitted with an interlocking switch that only allows its activation when the door is closed and locked.

Emergency stop switches, on the other hand, are devices used to immediately stop a machine in case of emergency. These switches are fitted in easily accessible places and are activated by quick and firm pressure. Emergency stop switches are crucial devices to prevent serious injuries and even death in case of accidents.

They are essential to ensure the safety of workers and machinery in industrial environments. By preventing workers getting hurt and damage to equipment they also serve to enhance factory efficiency and productivity.





DMS Series Slimline









Versatile housed, magnetic or RFID switches with extensive detection area.

Emergency stop switches are devices designed to immediately stop machine or equipment operation in dangerous or emergency situations.



Operating principle	Magnetic RFID
 Protection rating	IP68 (24 h/1 m)
 Standards	IEC 60947-5-3 EN 13849-1 IEC 61508
 EN ISO 138489-1: 2008	PLe Level 4
 EN ISO 62061 *Depending on the model	SIL CL 3 1,9x10e-9 SIL CL 3 2,7x10e-9 SIL CL 2 2,1x10e-9
 EN60947-1 utilization category	DC-12

 Function indicator	Green LED Red LED
 Supply voltage	24 V
 Operating temperature	-25 ... 70 °C
 Connections	Cable + M12 connector Cable
 Cable diameter	5.5 mm
 Short-circuit detection	Yes Not with Relay output
 Housing material	PBT

Technical specifications

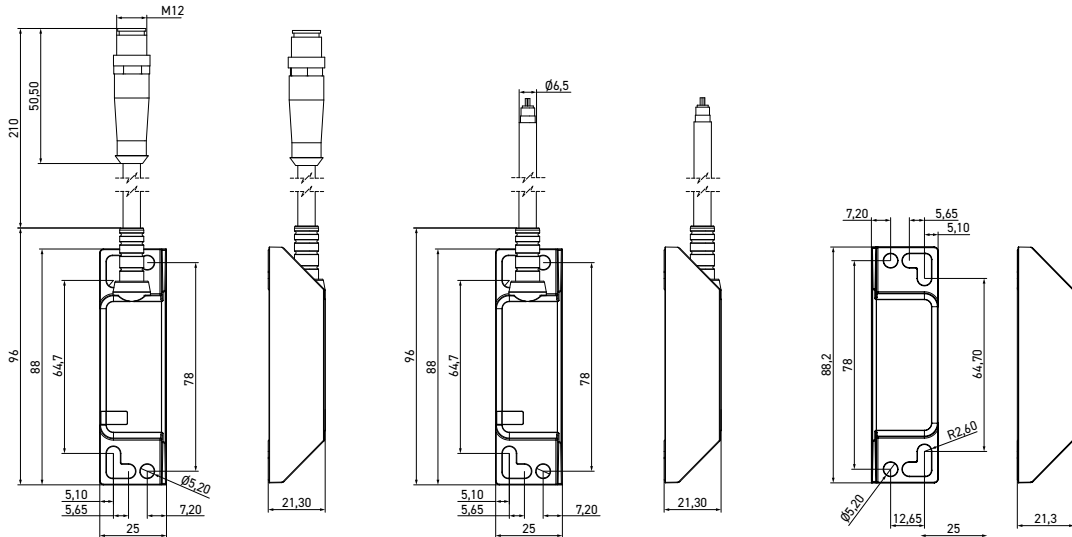

M12 - 8-pin	Pin	Cable	Function	Description
	1	White	S11*	Channel 1 safety input
	2	Brown	A1	Supply voltage
	3	Orange	S22	OSSD2: Channel 2 safety output
	4	Black	S12	OSSD1: Channel 1 safety output
	5	Grey	Y32	Auxiliary output (indicator function, without safety function)
	6	Pink	S21*	Channel 2 safety input
	7	Blue	A2	GND
	8	Red	INM	Electromagnet control input

*Only for sensors with enabled inputs



Reference	Operating principle	Output cable	Pins	Cable length	Detection distance	Disconnection distance	Outputs	Number of inputs	Detector weight	Actuator weight
DMS MOPN CK8 ER	Magnetic	Cable + M12	8	15 cm	12 mm	15 mm	2 x OSSD (PNP + NPN)	0	40 g	60 g
DMS MOPP CK8 ER	Magnetic	Cable + M12	8	15 cm	12 mm	15 mm	2 x OSSD (2x PNP)	0	40 g	60 g
DMS M2PN CK8 ER	Magnetic	Cable + M12	8	15 cm	12 mm	15 mm	2 x OSSD (PNP + NPN)	2	40 g	60 g
DMS M2PP CK8 ER	Magnetic	Cable + M12	8	15 cm	12 mm	15 mm	2 x OSSD (2x PNP)	2	40 g	60 g
DMS M3RL CK8 ER	Magnetic	Cable + M12	8	15 cm	12 mm	15 mm	2 x 1A Relay		130 g	60 g
DMS ROPN CK8 ER	RFID	Cable + M12	8	15 cm	18 mm	22 mm	2 x OSSD (PNP + NPN)	0	70 g	40 g
DMS ROPP CK8 ER	RFID	Cable + M12	8	15 cm	18 mm	22 mm	2 x OSSD (2x PNP)	0	70 g	40 g
DMS R2PN CK8 ER	RFID	Cable + M12	8	15 cm	18 mm	22 mm	2 x OSSD (PNP + NPN)	2	70 g	40 g
DMS R2PP CK8 ER	RFID	Cable + M12	8	15 cm	18 mm	22 mm	2 x OSSD (2x PNP)	2	70 g	40 g
DMS MOPN W02 ER	Magnetic	Cable		2 m	12 mm	15 mm	2 x OSSD (PNP + NPN)	0	130 g	60 g
DMS MOPP W02 ER	Magnetic	Cable		2 m	12 mm	15 mm	2 x OSSD (2x PNP)	0	130 g	60 g
DMS M2PN W02 ER	Magnetic	Cable		2 m	12 mm	15 mm	2 x OSSD (PNP + NPN)	2	130 g	60 g
DMS M2PP W02 ER	Magnetic	Cable		2 m	12 mm	15 mm	2 x OSSD (2x PNP)	2	130 g	60 g
DMS M3RL W02 ER	Magnetic	Cable		2 m	12 mm	15 mm	2 x 1A Relay		130 g	60 g
DMS ROPN W02 ER	RFID	Cable		2 m	18 mm	22 mm	2 x OSSD (PNP + NPN)	0	160 g	40 g
DMS ROPP W02 ER	RFID	Cable		2 m	18 mm	22 mm	2 x OSSD (2x PNP)	0	160 g	40 g
DMS R2PN W02 ER	RFID	Cable		2 m	18 mm	22 mm	2 x OSSD (PNP + NPN)	2	160 g	40 g
DMS R2PP W02 ER	RFID	Cable		2 m	18 mm	22 mm	2 x OSSD (2x PNP)	2	160 g	40 g
DMS MOPN W05 ER	Magnetic	Cable		5 m	12 mm	15 mm	2 x OSSD (PNP + NPN)	0	130 g	60 g
DMS MOPP W05 ER	Magnetic	Cable		5 m	12 mm	15 mm	2 x OSSD (2x PNP)	0	130 g	60 g
DMS M2PN W05 ER	Magnetic	Cable		5 m	12 mm	15 mm	2 x OSSD (PNP + NPN)	2	130 g	60 g
DMS M2PP W05 ER	Magnetic	Cable		5 m	12 mm	15 mm	2 x OSSD (2x PNP)	2	130 g	60 g
DMS M3RL W05 ER	Magnetic	Cable		5 m	12 mm	15 mm	2 x 1A Relay		130 g	60 g
DMS ROPN W05 ER	RFID	Cable		5 m	18 mm	22 mm	2 x OSSD (PNP + NPN)	0	160 g	40 g
DMS ROPP W05 ER	RFID	Cable		5 m	18 mm	22 mm	2 x OSSD (2x PNP)	0	160 g	40 g
DMS R2PN W05 ER	RFID	Cable		5 m	18 mm	22 mm	2 x OSSD (PNP + NPN)	2	160 g	40 g
DMS R2PP W05 ER	RFID	Cable		5 m	18 mm	22 mm	2 x OSSD (2x PNP)	2	160 g	40 g

DMS/S Series

Compact



Really compact magnetic or RFID safety switches.



Operating principle	Magnetic RFID
Protection rating	IP68 (24 h/1 m)
Standards	IEC 60947-5-3 EN 13849-1 IEC 61508
EN ISO 138489-1: 2008	PLe Level 4
EN ISO 62061 *Depending on the model	SIL CL 3 1,9x10e-9 SIL CL 3 2,7x10e-9
EN60947-1 utilization category	DC-12

Function indicator	Green LED Red LED
Supply voltage	24 V
Operating temperature	-25 ... 70 °C
Connections	Cable + M12 connector Cable
Cable diameter	5.5 mm
Short-circuit detection	Yes
Housing material	PBT

Technical specifications

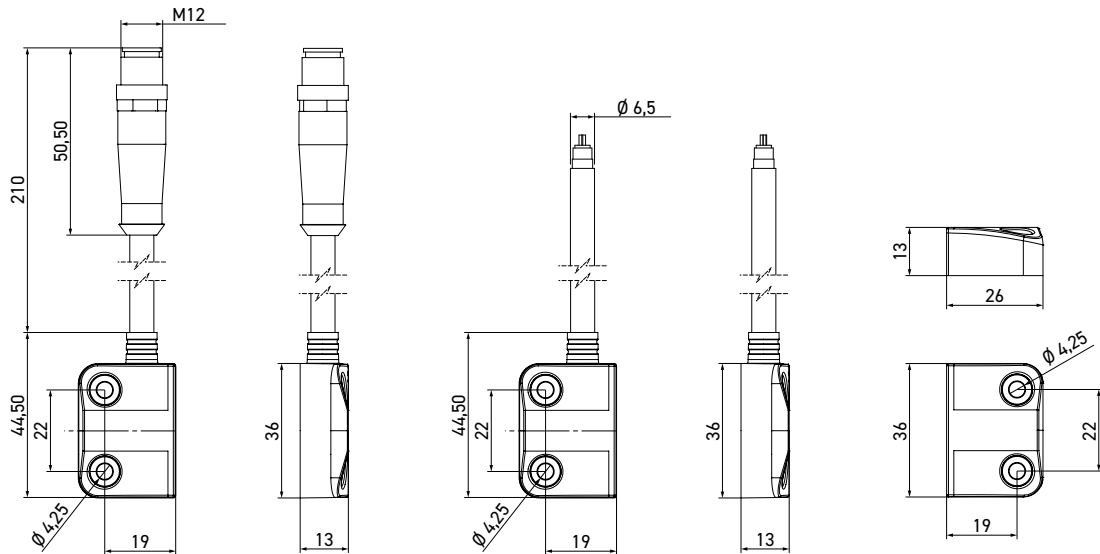

M12 - 8-pin	Pin	Cable	Function	M12 - 4-pin	Pin	Cable	Function
	1	White	SI*1 - Channel 1 safety input		1	Brown	A1 - Supply voltage
	2	Brown	A1 - Supply voltage		2	White	SI2 - Channel 1 safety output
	3	Orange	S22 - OSSD2: Channel 2 safety output		3	Blue	A2 - GND
	4	Black	SI2 - OSSD1: Channel 1 safety output		4	Black	S22 - Channel 2 safety output
	5	Grey	Y32 - Auxiliary output (indicator function, without safety function)				
	6	Pink	S21* - Channel 2 safety input				
	7	Blue	A2 - GND				
	8	Red	Not connected				

*Only for sensors with enabled inputs

Reference	Operating principle	Output cable	Pins	Cable length	Detection distance	Disconnection distance	Outputs	Number of inputs	Detector weight	Actuator weight
DMS/S MOPN CK8 ER	Magnetic	Cable + M12	8	15 cm	6 mm	8 mm	2 x OSSD (PNP + NPN)	0	40 g	25 g
DMS/S MOPP CK8 ER	Magnetic	Cable + M12	8	15 cm	6 mm	8 mm	2 x OSSD (2x PNP)	0	40 g	25 g
DMS/S M2PN CK8 ER	Magnetic	Cable + M12	8	15 cm	6 mm	8 mm	2 x OSSD (PNP + NPN)	2	40 g	25 g
DMS/S M2PP CK8 ER	Magnetic	Cable + M12	8	15 cm	6 mm	8 mm	2 x OSSD (2x PNP)	2	40 g	25 g
DMS/S ROPN CK8 ER	RFID	Cable + M12	8	15 cm	8 mm	9 mm	2 x OSSD (PNP + NPN)	0	40 g	15 g
DMS/S ROPP CK5 001 ER	RFID	Cable + M12	4	15 cm	8 mm	9 mm	2 x OSSD (2x PNP)	0	40 g	15 g
DMS/S ROPP CK8 ER	RFID	Cable + M12	8	15 cm	8 mm	9 mm	2 x OSSD (2x PNP)	0	40 g	15 g
DMS/S R2PN CK8 ER	RFID	Cable + M12	8	15 cm	8 mm	9 mm	2 x OSSD (PNP + NPN)	2	40 g	15 g
DMS/S R2PP CK8 ER	RFID	Cable + M12	8	15 cm	8 mm	9 mm	2 x OSSD (2x PNP)	2	40 g	15 g
DMS/S MOPN W02 ER	Magnetic	Cable		2 m	6 mm	8 mm	2 x OSSD (PNP + NPN)	0	130 g	25 g
DMS/S MOPP W02 ER	Magnetic	Cable		2 m	6 mm	8 mm	2 x OSSD (2x PNP)	0	130 g	25 g
DMS/S M2PN W02 ER	Magnetic	Cable		2 m	6 mm	8 mm	2 x OSSD (PNP + NPN)	2	130 g	25 g
DMS/S M2PP W02 ER	Magnetic	Cable		2 m	6 mm	8 mm	2 x OSSD (2x PNP)	2	130 g	25 g
DMS/S ROPN W02 ER	RFID	Cable		2 m	8 mm	9 mm	2 x OSSD (PNP + NPN)	0	130 g	15 g
DMS/S ROPP W02 ER	RFID	Cable		2 m	8 mm	9 mm	2 x OSSD (2x PNP)	0	130 g	15 g
DMS/S R2PN W02 ER	RFID	Cable		2 m	8 mm	9 mm	2 x OSSD (PNP + NPN)	2	130 g	15 g
DMS/S R2PP W02 ER	RFID	Cable		2 m	8 mm	9 mm	2 x OSSD (2x PNP)	2	130 g	15 g
DMS/S MOPN W05 ER	Magnetic	Cable		5 m	6 mm	8 mm	2 x OSSD (PNP + NPN)	0	130 g	25 g
DMS/S MOPP W05 ER	Magnetic	Cable		5 m	6 mm	8 mm	2 x OSSD (2x PNP)	0	130 g	25 g
DMS/S M2PN W05 ER	Magnetic	Cable		5 m	6 mm	8 mm	2 x OSSD (PNP + NPN)	2	130 g	25 g
DMS/S M2PP W05 ER	Magnetic	Cable		5 m	6 mm	8 mm	2 x OSSD (2x PNP)	2	130 g	25 g
DMS/S ROPN W05 ER	RFID	Cable		5 m	8 mm	9 mm	2 x OSSD (PNP + NPN)	0	130 g	15 g
DMS/S ROPP W05 ER	RFID	Cable		5 m	8 mm	9 mm	2 x OSSD (2x PNP)	0	130 g	15 g
DMS/S R2PN W05 ER	RFID	Cable		5 m	8 mm	9 mm	2 x OSSD (PNP + NPN)	2	130 g	15 g
DMS/S R2PP W05 ER	RFID	Cable		5 m	8 mm	9 mm	2 x OSSD (2x PNP)	2	130 g	15 g

DMS/5 Series



Exceptional versatility and reliability

RFID safety switches, the 4 sensing faces of which endow them with greater mounting versatility.



Operating principle	RFID
Protection rating	IP68 (24 h/1 m)
Standards	IEC 60947-5-3 EN 13849-1 IEC 61508
EN ISO 138489-1: 2008	PLe Level 4 High encryption level
EN ISO 62061	SIL CL 3 PFHD 2.7x10e-9
EN60947-1 utilization category	DC-12
Detection distance	15 mm
Disconnection distance	20 mm

Function indicator	Green LED Red LED
Supply voltage	24 V
Operating temperature	-25 ... 70 °C
Connections	M12 connector
Short-circuit detection	Yes
Housing material	PBT
Safety detector weight	120 g
Actuator weight	15 g

Four operating directions for enhanced versatility



Steady green light indicates device activation.



Disconnection is indicated by flashing red LED indicators.



M12 - 8-pin	Pin	Cable	Function
	1	White	SI*1 - Channel 1 safety input
	2	Brown	A1 - Supply voltage
	3	Orange	S22 - OSSD2: Channel 2 safety output
	4	Black	SI2 - OSSD1: Channel 1 safety output
	5	Grey	Y32 - Auxiliary output (indicator function, without safety function)
	6	Pink	S21* - Channel 2 safety input
	7	Blue	A2 - GND
	8	Red	Not connected
*Only for sensors with enabled inputs			

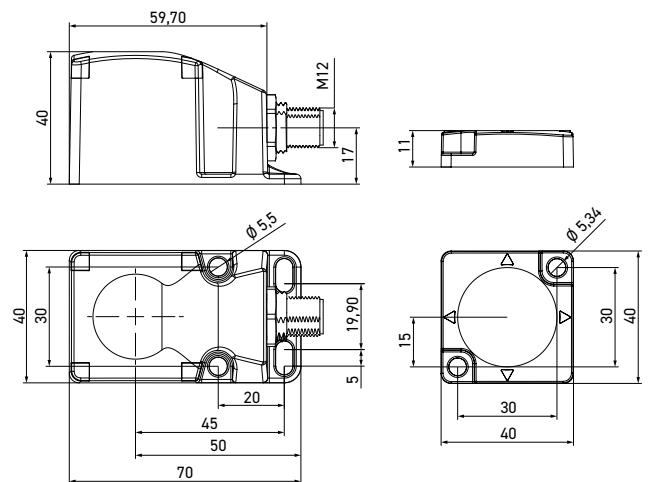

Reference	Output cable	Pins	Connection types	Number of inputs
DMS/5 ROPN C08 ER	M12 connector	8	2 x OSSD (PNP + NPN)	0
DMS/5 ROPP C08 ER	M12 connector	8	2 x OSSD (2x PNP)	0
DMS/5 R2PN C08 ER	M12 connector	8	2 x OSSD (PNP + NPN)	2
DMS/5 R2PP C08 ER	M12 connector	8	2 x OSSD (2x PNP)	2

DMS/M Series

Door locking protection systems



Up to **100 kg**
holding force

An RFID switch with a magnetic locking function up to a holding force of 100 kg to prevent the opening of neutralisation or manipulation safety guards.



www.tuv.com
ID 060000000

Encryption for maximum protection against manipulation.

Protection during the magnetic locking process.

Tolerance with respect to protection door misalignment.

Flexible connection via connectors.

Optimised energy efficiency magnet to reduce

















energy consumption.

Door protection systems to control the position of moving protection devices in accordance with EN 60947-5-3.

For up to PLe applications in accordance with EN ISO 13849-1, SIL CL 3 in accordance with EN/ IEC 62061 with magnetic locking for process protection tasks.

Serial connection up to PLe in accordance with EN ISO 13849-1.

General characteristics

 Operating principle	RFID	 Distance between detectors	30 mm
 Protection rating	IP68 (24 h/1 m)	 Function indicator	Error identification via LEDs placed on the side faces
 Standards	IEC 60947-5-3 EN 13849-1 IEC 61508	 Supply voltage	24 V
 EN ISO 138489-1: 2008	PLe Level 4 High encryption level	 Safety output type	OSSD
 EN ISO 62061	SIL CL 3 2.6x10e-9	 Operating temperature	-25 ... 70 °C
 EN60947-1 utilization category	DC-12	 Connections	8-pin - M12 connector
 Disconnection distance	30 mm	 Short-circuit detection	Yes
 Switching frequency	< 1Hz	 Housing material	PBT PBT, Aluminium



Visual diagnosis

All models come with simple LED diagnosis indicators on both sides.

- ▶ Operation sensor
- ▶ Input status
- ▶ Sensor module status
- ▶ Electromagnet status

Two types of confinement

No voltage (N) and voltage. Two versions from which to choose magnetic remanence.

'N' series models are versions in which magnetism is permanent, thus voltage needs to be applied to release this residual magnetism. This is particularly useful when you need to block access during power failures or voltage dips for safety reasons.

Locking by padlock

This is a combined solution to control protection door safety by means of a padlock to prevent unwitting or mistaken locking of the device.

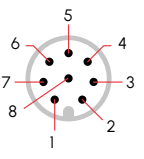
M12 - 8-pin	Pin	Cable	Function	Description
	1	White	S11*	Channel 1 safety input
	2	Brown	A1	Supply voltage
	3	Orange	S22	OSSD2: Channel 2 safety output
	4	Black	S12	OSSD1: Channel 1 safety output
	5	Grey	Y32	Auxiliary output (indicator function, without safety function)
	6	Pink	S21*	Channel 2 safety input
	7	Blue	A2	GND
	8	Red	INM	Electromagnet control input
*Only for sensors with enabled inputs				





DMS/M

Voltage
Holding force: 100 kg
Emitter weight: 650 g
Receiver weight: 1.2 kg

Reference	Outputs	Inputs
DMS/M ROPP C08 ER	2xOSSD (2xPNP)	0
DMS/M R2PP C08 ER	2xOSSD (2xPNP)	2

DMS/M 002

Voltage
Holding force: 100 kg
Emitter weight: 650 g
Receiver weight: 1.2 kg

Reference	Outputs	Inputs
DMS/M ROPP C08 002 ER	2xOSSD (2xPNP)	0
DMS/M R2PP C08 002 ER	2xOSSD (2xPNP)	2

DMS/MN

No voltage
Holding force: 60 kg
Emitter weight: 650 g
Receiver weight: 1.2 kg

Reference	Outputs	Inputs
DMS/MN ROPP C08 ER	2xOSSD (2xPNP)	0
DMS/MN R2PP C08 ER	2xOSSD (2xPNP)	2

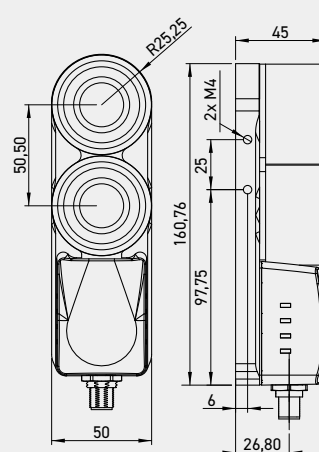
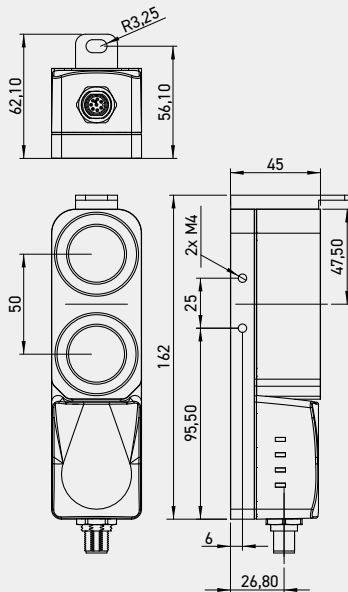
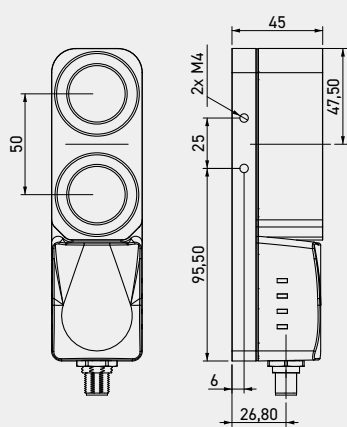
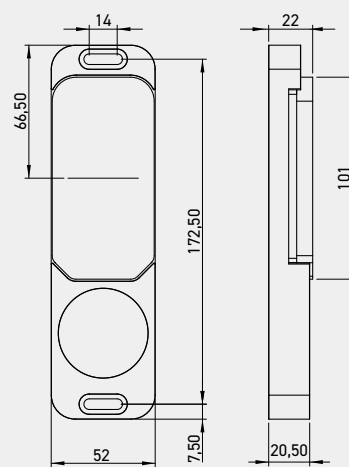
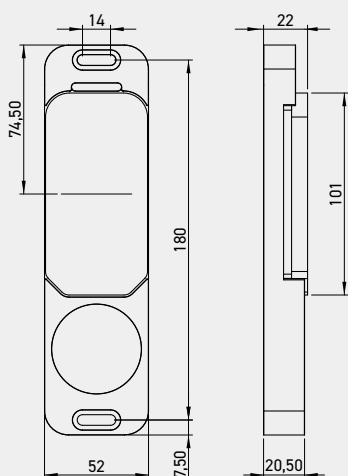
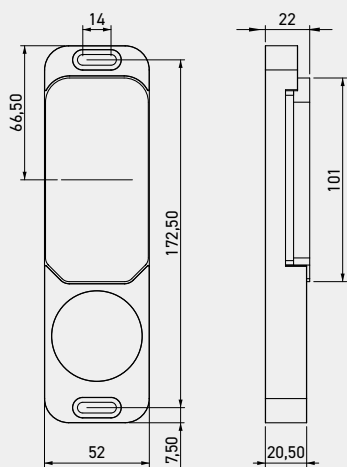

Technical specifications



DMS/MN 002		
Voltage		
Holding force: 60 kg		
Emitter weight: 450 g		
Receiver weight: 640 g		
Reference	Outputs	Inputs
DMS/MN ROPP C08 002 ER	2xOSSD (2xPNP)	0
DMS/MN R2PP C08 002 ER	2xOSSD (2xPNP)	2

DMS/M1		
Voltage		
Holding force: 50 kg		
Emitter weight: 450 g		
Receiver weight: 640 g		
Reference	Outputs	Inputs
DMS/M1 ROPP C08 ER	2xOSSD (2xPNP)	0
DMS/M1 R2PP C08 ER	2xOSSD (2xPNP)	2

DMS/MIN		
No voltage		
Holding force: 30 kg		
Emitter weight: 450 g		
Receiver weight: 640 g		
Reference	Outputs	Inputs
DMS/MIN ROPP C08 ER	2xOSSD (2xPNP)	0
DMS/MIN R2PP C08 ER	2xOSSD (2xPNP)	2

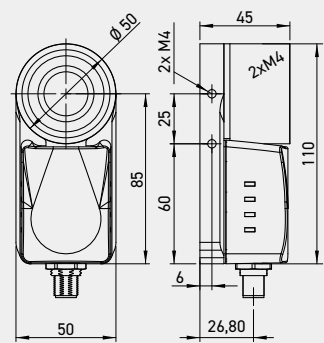
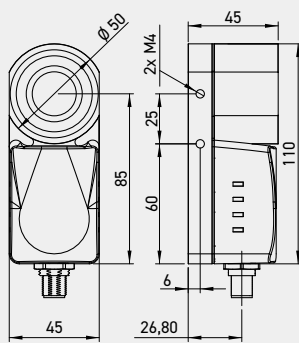
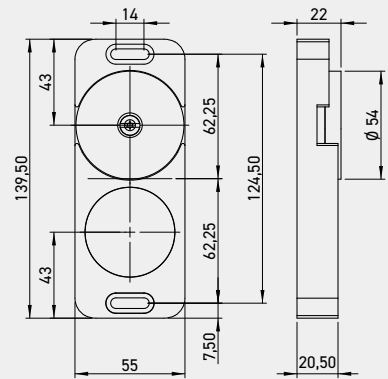
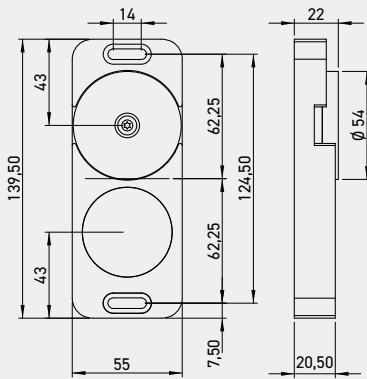
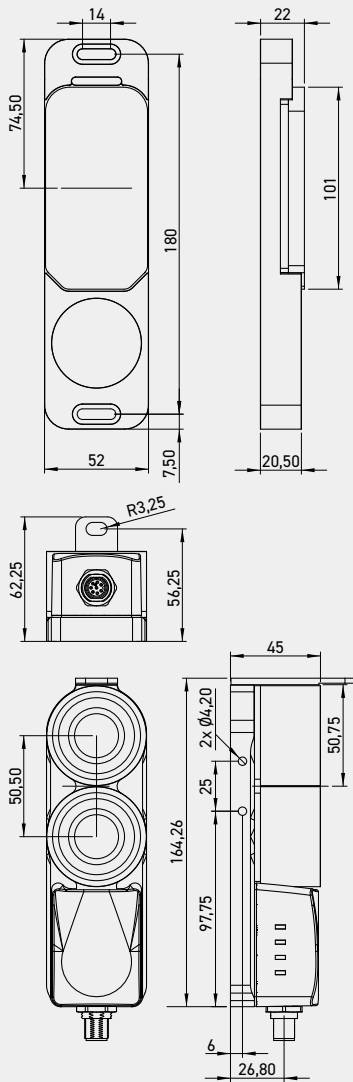



RSM 003E1

Safety relay

This is especially designed for use as a TÜV Rheinland certified safety component.

For applications that include one or two channel emergency stop circuits and to control machine and installation safety guards.



www.tuv.com
ID 0600000000

3 non-delayed safety contacts.
1 non-delayed auxiliary contact.

Connecting of:

Emergency pushbuttons.
Mechanical safety switches.
Contactless safety switches.
Safety components with OSSD outputs.

Control: one or two channels.

Feedback loop for external contacts and extension modules.

Cyclic control of output contacts.

ON and status LED indicators.

Automatic or manual start-up.

Short-circuit and earth fault monitoring.

Up to PL_e, SILCL 3, level 4:
EN ISO 13849-1
EN 62061
EN 61508

Technical specifications

Standards	EN 60204-1 EN ISO 13849-1 IEC 62061 IEC 61508 Parts 1-2 and 4-7
TÜV certification	Yes
Supply voltage	DC 24 V +/- 10%
Energy consumption	2.6 W
Max. input current	5 A (approx. 250 µs)
Pulse suppression	(A1 / S12 / S14) OFF pulse / dark test: max. 3 ms (pulse width) / 500 ms (pulse frequency) Pulse test / ON light: max. 1 ms (pulse width) / 500 ms (pulse frequency) Note: Care must be taken that the ON pulses (light test) sent by the signal generator do not cause brief safety relay activation and, therefore, must be basically deactivated.
Contact configuration	3 NO (Safety contacts) / 1 NC (auxiliary contact)
Max. switching voltage	AC 250 V
Safety contacts	(13-14, 23-24, 33-34) 6 switching cycles / min AC: 250 V, 2000 VA, 8 A for resistive load 250 V, 3 A for AC-15 DC: 30 V, 240 W, 8 A for resistive load 24 V, 3 A for DC-13
Thermal current (I _{th})	Max. 5 A per contact (see total current limitation curve)

Auxiliary contact	(41-42) AC: 250 V, 500 VA, 2 A for resistive load DC: 30 V, 60 W, 2 A for resistive load
Minimum contact load	5 V, 10 mA
External fuses	10 A gG (NO); 6 A gG (NC)
Max. ON delay	< 50 ms
Max. OFF delay	Via A1: < 40 ms Via S12 or S13/S14: < 20 ms
Recovery time	< 500 ms
Cable section	0.14 - 2.5 mm ²
Tightening torque (min./max.)	0.5 Nm / 0.6 Nm
Contact material	AgSnO ₂
Service life	Approx. 1 x 10 ⁷
Nominal voltage withstood by pulse	2.5 kV (control voltage / contacts)
Dielectric strength	4 kV (DIN VDE 0110-1)
Nominal isolation voltage	250 V
Pollution rating / Overload category	2 / 3 (DIN VDE 0110-0)
Protection rating	IP20
Operating temperature	-15 °C...+55 °C
Storage temperature range	-15 °C...+85 °C
Maximum height	≤ 2000 m
Weight	Approx. 150 g
Mounting	DIN rail in accordance with EN 60715 TH35

The RSM 003E1 relay is designed to isolate safety circuits in accordance with EN 60204-1, stop category 0 and can be used for safety applications of up to safety level 4, PL_e (EN ISO 13849-1) SILCL 3 (EN 62061/EN 61508) .

As per EN 60204-1, the device is designed for installation in switchboard cubicles with a minimum protection rating of IP54. The following must be taken into account:

- ▶ 35 mm mounting rail in accordance with EN 60715
- ▶ Make sure there is sufficient heat dissipation in the control cabinet
- ▶ Minimum distance from adjoining devices as per the total current limitation curve

Dimensions

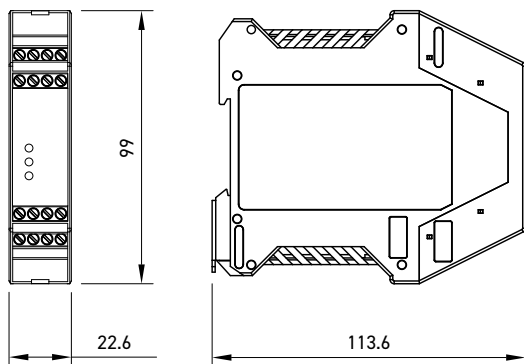

Electrical connection

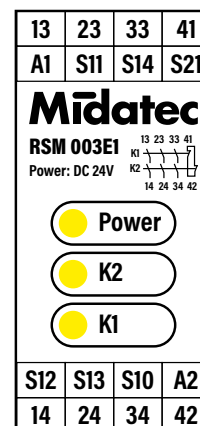

- A1: Power supply (24V)
- A2: Power supply (0V)
- S11: Control voltage
- S10: Control line
- S21: Start control line
- S13: Control line
- S14: Control line
- S12: Control line
- 13-14: Safety contact 1
- 23-24: Safety contact 2
- 33-34: Safety contact 3
- 41-42: Auxiliary contact

VISION SENSORS

SV1 & SVIC Series

Monochrome and colour



SVA Smart Vision Assistant

Make the most of SV1 and SVIC sensors.

Software designed for easy and comfortable inspection work

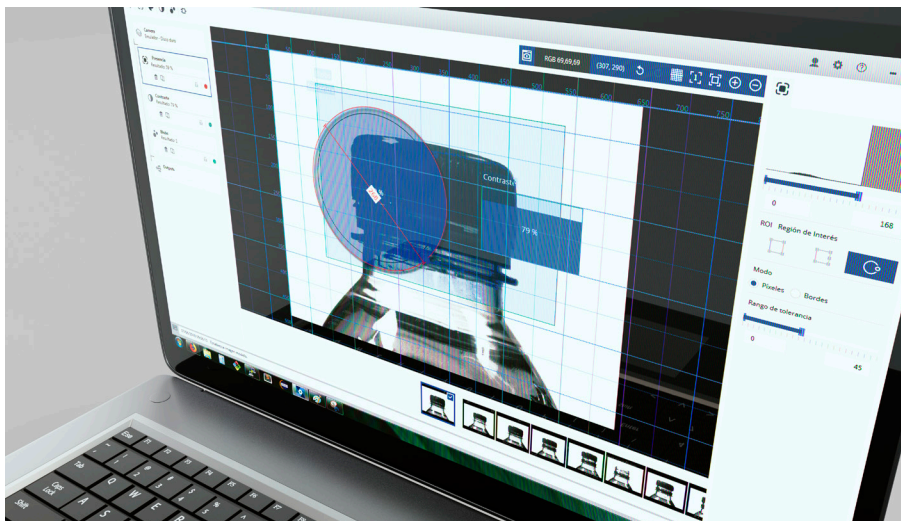

Automate using smart vision

Object recognition, inspection and checking

An industrial smart vision sensor is an electronic device that uses image processing technology to capture, process and analyse images of objects in industrial environments. These sensors can be used for a wide range of purposes, such as quality control, process control and object detection.

Smart sensors are designed to work in exacting industrial environments, such as factories, production plants and warehouses. They are fitted with high-resolution cameras and state-of-the-art image processing software that enable real-time analysis and decision-making based on the information provided by the images.

Among just some of the most important features of smart vision sensors are: the capacity to work with different types of lighting; the capacity to process images at high speed; the capacity to take accurate measurements of the target object; and the capacity to detect and classify objects in different environments.

In short, vision sensors are key tools for automating and controlling processes in industrial environments, enabling as they do the speedy and accurate capturing and processing of information, thereby enhancing efficiency and productivity.

Some of the most common uses of smart vision sensors are:

Quality control

To detect flaws in manufactured parts or products, such as cracks, scrapes, dents, etc. They can also be used to check whether products meet the quality and technical standards.

Process control

To monitor and control production processes, ensuring that parts are properly assembled and that products are made to spec.

Verifying labels and barcodes

To read and check product labels and barcodes, making sure they have been properly labelled and that the information matches that in the database.

Monitoring objects

To monitor objects in movement, for example, in transport and logistics systems. This can help to ensure that objects reach their destination safely and efficiently.

Guiding and positioning

To guide and position objects on production lines, making sure they are placed in the right position before subsequent manipulation.

Safety

To monitor and detect foreign bodies or hazardous objects in the workplace, such as, for example, objects that may fall or operators may knock against.

SV1 & SV1C Series



ALL-IN-ONE

VISION SENSORS FOR INDUSTRIAL USE

Object recognition, inspection and checking for numerous industrial purposes

RELIABLE AND EXCEPTIONALLY VERSATILE

Unrivalled accuracy in detecting small parts.

Vision sensors are designed for easy installation and use.

Lighting, optical system, evaluation and logical output components are integrated into a housing ideal for use in industrial environments.

COLOUR

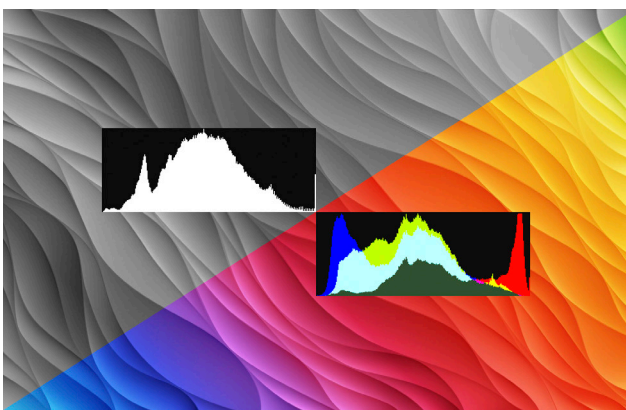

MISS NOTHING BY EXTENDING THE DYNAMIC RANGE.

Unlike the monochrome version, which identifies a range of intensities between black and white extremes, the colour model separates light information received into the three primary spectrum colours (RGB). The intensity range of each colour is then identified to produce subtle distinctions, even when the colours return minimal intensity differences.

A colour model provides decisive information that proves much clearer than that provided by a monochrome image.

As can be seen in the comparison between the circled areas, you can hardly distinguish variations using the grey scale of values.



FULLY EQUIPPED WITH STANDARD FEATURES

4GB

Flash Memory

512MB

DDR3 RAM

WVGA

752 x 480

54 FPS

High speed

32 slots

Workspace

10/100 Mbps

Ethernet connectivity
4-pin, M12 female connector

Strong, very strong

- ▶ IP67 protection rating compliant thus guaranteeing water tightness and protection against dust.
- ▶ Compact, ultra-resistant, machined aluminium housing.

Quick, very quick

- ▶ 4x Arm® Cortex®-A9 processor up to 1.2 GHz per core.

Colour. SVIC

- ▶ SVIC cameras detect colours and can also perform the same tasks as its sister product, the SVI, such as, for example, comparing patterns, detecting contours, detecting glare, grey thresholds and contrast.

Technology

Self-focusing system with no moving parts

- ▶ Self-focusing system without moving parts, providing fully compact focusing, thus ensuring lens cleanliness by avoiding manipulation, not to mention its robustness, water tightness, durability and focus speed.

Integrated LED lighting

- ▶ Neutral white (4500°K)
- ▶ Red (660 nm)
- ▶ Infrared (850 nm)

Communication Modbus

- ▶ Open and highly reliable Modbus
- ▶ Wide range of industrial uses
- ▶ Supports a wide range of PLCs

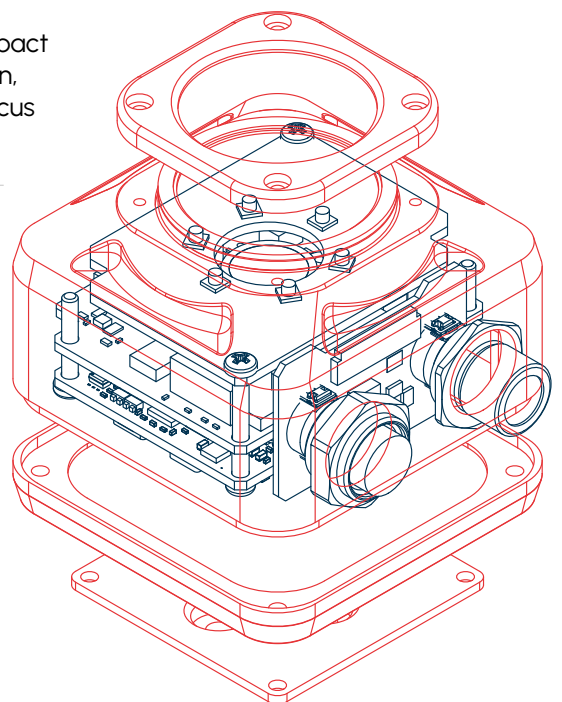

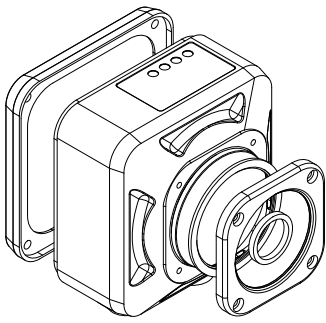

Liquid lens technology

SELF-FOCUSING SYSTEM WITH NO MOVING PARTS

Liquid lens based, self-focusing technology enables the sensor to automatically adapt to work distances, while software allows it to focus on the peculiarities of the object being inspected.

Its special self-focusing lens uses a novel focusing system that applies a modulated electrical field on electrical charges which enables changes to the refraction properties of the liquid lens components, thereby controlling the focus point.

Unlike zoom lenses, liquid lenses have no moving parts, thus precluding mechanical wear and tear. This simplifies installation, setting and maintenance as there is no need to handle the lens manually.

Moreover, its extremely fast response times and outstanding optical quality are particularly noteworthy.

It is ideal for varying inspection distances between different parts and for use during part changes.

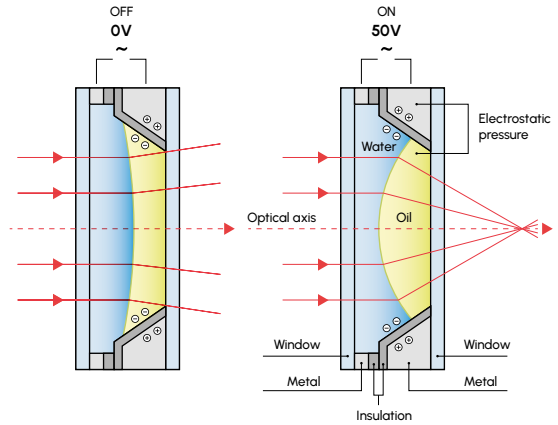

Connections

Connectivity Solutions for Sensor Devices

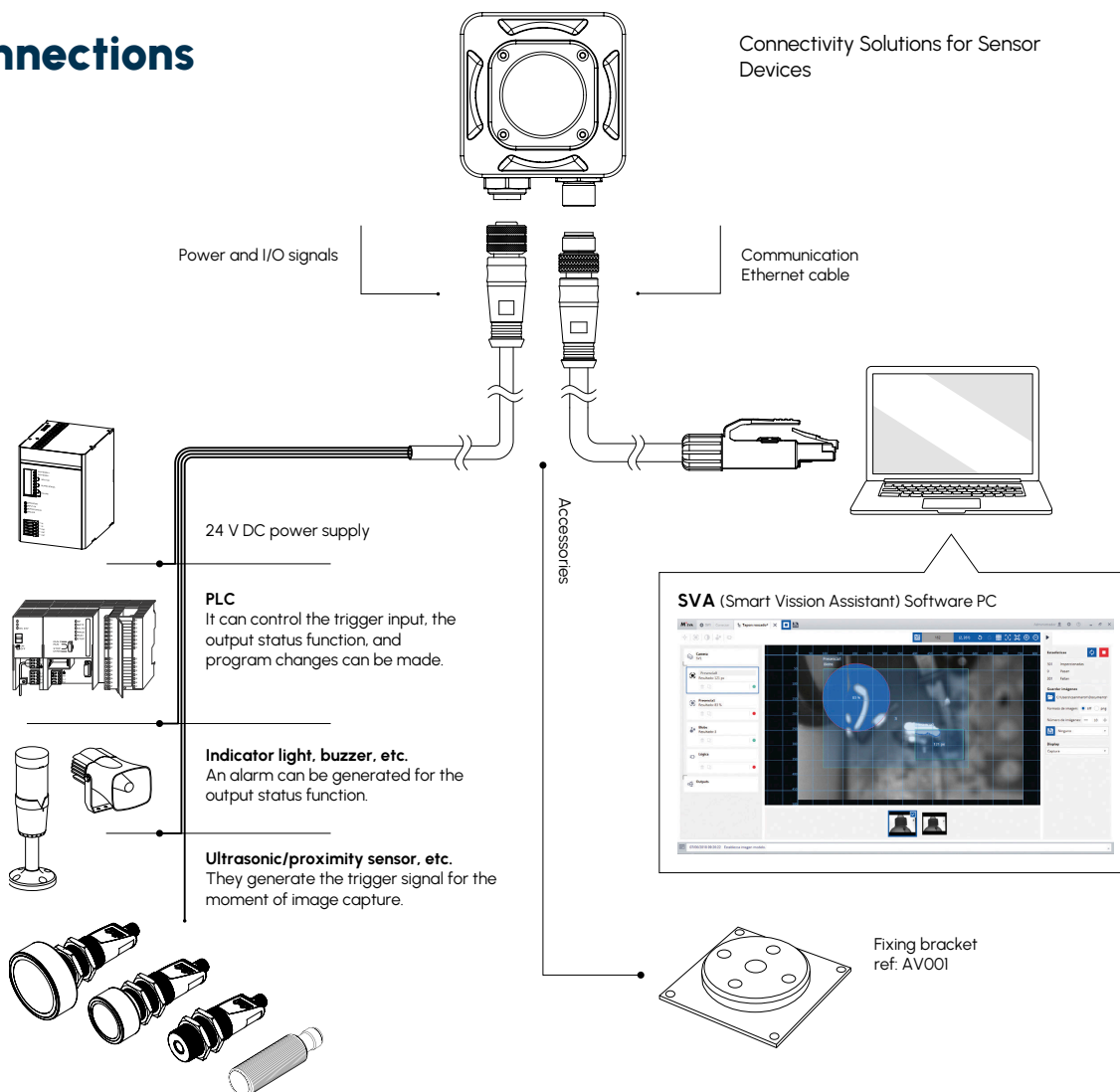



Broaden possibilities

Customised developments

Stretching use horizons, the SVI vision sensor opens up a world of possibilities to develop solutions and customise features.

Hardware and Software

Algorithm adaptation for available tools

Very high speed. Reducing image resolution to meet optimal needs.

Resolution	FPS	PPM
752x480	54	3600
376x240	118	7080
180x120	170	10200

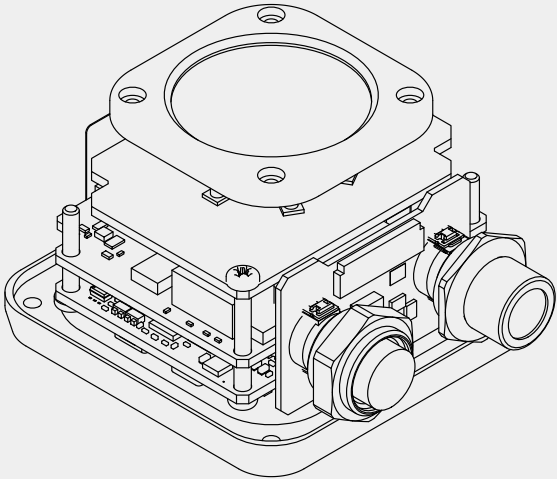

Setting options

SVI vision sensors are designed as an open system.

This allows for different adjustment and settings to meet particular industrial needs.

- ▶ **Processor**
2x Arm® Cortex®-A9 processor up to 1.2 GHz per core.
- ▶ MI2 lens
- ▶ **Transfer speed**
Ethernet: 1Gbps
- ▶ **Storage**
4, 8, 16, 32 or 64 GB
- ▶ Digital outputs up to 200 mA
- ▶ Configurable strobe output
- ▶ Configurable strobe output to use external flash
- ▶ **Power over Ethernet (PoE)** No need for nearby power sockets near the powered device.
- ▶ Lighting colour composition
Select lighting. Colour and intensity.
- ▶ **Polarised lenses and filters**
- ▶ **Adapted resolution for high-speed inspection**
Sensor image resolution can be adapted to enhance inspection process speeds.

Technical specifications

Environment settings	
Operating temperature	0 ... 50 °C Internal protection against overheating.
Storage temperature	-40 ... 80 °C
Operating humidity	0 ... 90%, without condensation.
Max. operating altitude.	4000 m
Protection rating as per EN 60529	IP67
Technical features	
Housing material	Anodised aluminium
Weight with/without packaging	375/260 g
Applicable standards	Shock 80 Gs for 5 ms on each axis (as per IEC 68-2-27). Vibration 10 Gs (10-500 Hz) as per IEC 68-2-6.
Power input	
Supply voltage	24 Vdc ± 25% (18 ... 30 Vdc)
Consumption	250 mA @ 24 Vdc
Inputs	
Inputs with shared neutral for task change (up to 32)	2
Differential trigger input.	1
Optocoupled inputs	Yes
Reverse polarity protection	Yes
ON input voltage levels	8 ... 30 V ON Current @ 24 V = 11 mA
OFF input voltage levels	< 1 Vdc
Minimum response time	50 µs
Outputs	
Number of outputs	4 with shared point (configurable, assigned by user to different tools)
1 configurable output as strobe output to use external flash	Yes
Constant short circuit and reverse polarity protection.	Yes
Maximum digital output voltage	28 Vdc
Maximum output currents	50 mA throughout the Temp. range Up to 100 mA @ 25 °C
Maximum voltage drop	2 Vdc @ 50 mA throughout the Temp. range
Output type	4 x NPN or 4 x PNP, self-configurable.
Effective distance	1 m
Function indicators	
POWER/ERROR	Flashing green light, working properly Constant red, operating fault
PASS/FAIL	Verdict on the work being done by the camera - Green, pass - Red, fail
LINK/ACT	Ethernet activity link - Yellow, Ethernet link active - Flashing green, connection activity
TRIGGER	Yellow, when triggered externally
Communication	

Industrial Communications Protocol	Modbus TCP
Ethernet Connection	4-pin, M12 female connector
Power connection, inputs and outputs	12-pin, M12 female connector
Standards	
UNE-EN 60947-5-2	Electromagnetic compatibility
IEC 61000-4-2	Electrostatic discharge
IEC 61000-4-3	Radiated, radio-frequency, electromagnetic field immunity test
IEC 61000-4-4	Electrical fast transient/burst immunity test
IEC 61000-4-6	Immunity to conducted disturbances, induced by radio-frequency fields
IEC 61000-4-8	Power frequency magnetic field immunity test
IEC 68-2-27	Vibration 10 Gs Tests (10-500Hz)
IEC 68-2-6	Shock 80 Gs tests, 5 mS
Software	
Maximum capture speed	54 FPS
Operating modes	Autonomous and Set
Configuration software	Smart Vision Assistant
Software languages	Spanish / English / Catalan
Operating system	Windows 7 or later
Monitor	1024 x 768 or higher. Colour depth, 16-bit or higher
Slot system to change working mode in autonomous mode	Yes
Access security	By password, 3 user roles: administrator, designer and operator.
IP Addressing	IP defined by user or DHCP mode
Automatic detection of cameras connected online	Yes
Selection of the active job at camera start-up	Yes
Processing tools	
Pattern	- Looks for a given pattern via object contours or outline and can be used to position the other tools
Blobs/counter	- Quantifies the number of blobs, areas with the same intensity level.
Presence	- Determines the presence or absence of an object or edge depending on the selected intensity range.
Contrast	- Measures the difference between bright and dark areas inside a region.
Logic	- Evaluates a given logical condition to compose a complex output with the results of other tools.
Colour	- Colour is an important feature to detect differences and defects between objects in the production process, such as, for example, in the printing of colours and labels.
Measurement	- Checks a distance or angle inside a region.
Codes	- Decodes barcodes and 2D codes and enables their comparison with an expected text.
Storage	
FTP image storage	

Reference	Mono/colour	Image sensor	Lens	IR filter	Lighting
SVI 75B	MONO	Monochrome 1/3" 752x480 px	7.5 mm Self-focusing	NO	Neutral white (4500 K)
SVI 96B	MONO	Monochrome 1/3" 752x480 px	9.6 mm Self-focusing	NO	Neutral white (4500 K)
SVIC 75B	COLOUR	Colour 1/3" 752x480 px	7.5 mm Self-focusing	NO	Neutral white (4500 K)
SVIC 96B	COLOUR	Colour 1/3" 752x480 px	9.6 mm Self-focusing	NO	Neutral white (4500 K)



Connections

Digital inputs and outputs power supply.

- ▶ 12-pin - M12 male connector
- ▶ Power cable colour code as per DIN47100.

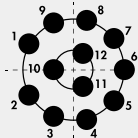

PIN	Description	Colour code
1	Input 1/ Trigger +	White
2	Input 1/ Trigger-	Brown
3	Input 2 / Encoder PhA +	Green
4	Input 3 / Encoder PhB +	Yellow
5	Common Input 2.3 / PhA, PhB -	Grey
6	Common Output -	Pink
7	Output 1 +	Blue
8	24 V +	Red
9	Power supply GND	Black
10	Output 2 +	Purple
11	Output 3 +	Grey/Pink
12	Output 4 +	Red/Blue

Ethernet connection.

- ▶ 4-pin - M12 female connector

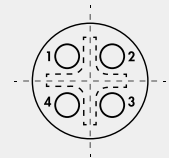

PIN	Description	Colour code
1	XA +	Yellow
2	XB +	White
3	XA -	Orange
4	XB -	Blue

Object recognition, inspection and checking

The focal length determines the camera angle of view and affects field depth, which is the distance between the nearest to the furthest object that appears focused in the image.

It is important to select the right focal length to ensure that clear and detailed images of the objects being inspected are captured.

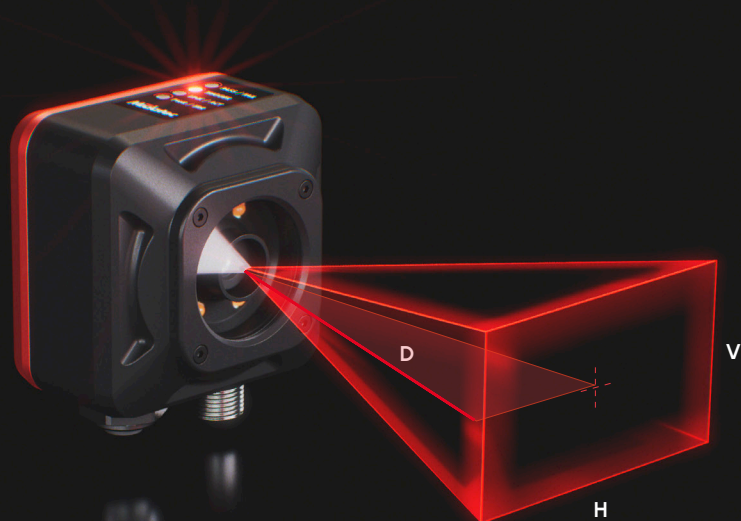

Focal lengths

7.5 mm and 9.6 mm

Focal	Angle			Field amplitude	
	Horizontal (H)	Vertical (V)	Diagonal (D)	Horizontal (H)	Vertical (V)
7.5 mm	35°	21°	41°	0.63*D	0.37*D
9.6 mm	28°	18°	33°	0.50*D	0.32*D

SMART VISION ASSISTANT

MIDATEC SVA

In-house software developed to enable working together with several tools.

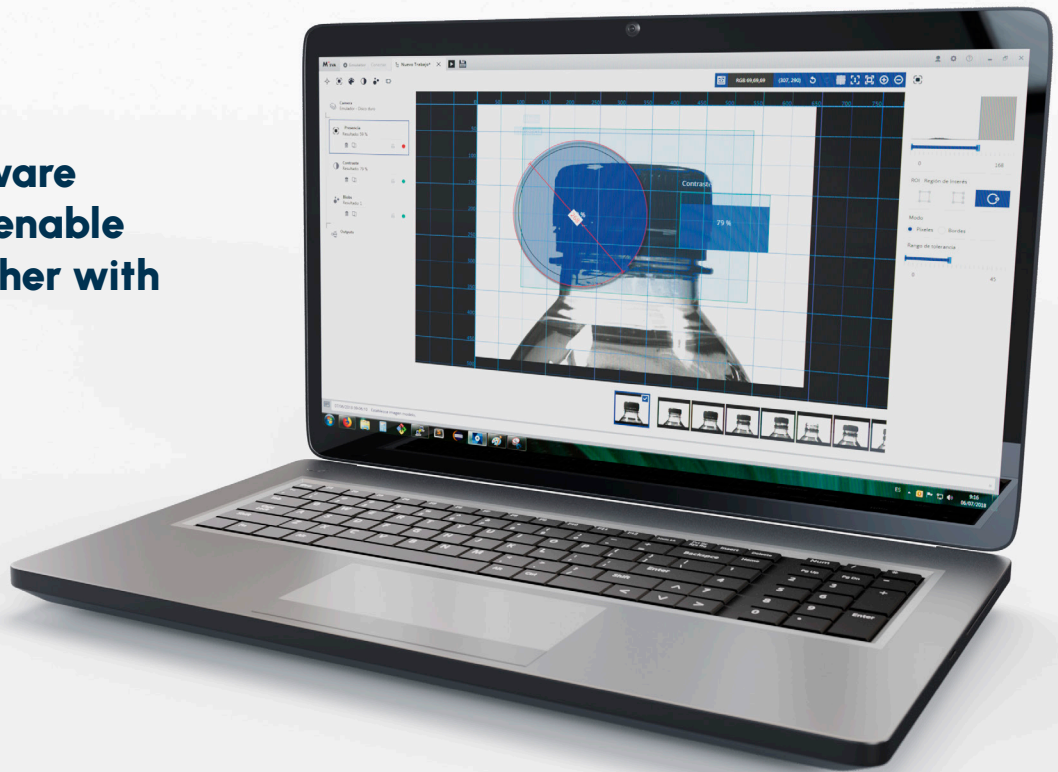

General camera settings

Creating jobs in Emulator mode

Configuring digital and virtual outputs

Focus Assistant

Checking work with live camera images

Capturing images to validate work

MAKE THE MOST OF THE SVI AND SVIC

- ▶ Configured by means of PC over the Ethernet, using Smart Vision Assistant configuration software.
- ▶ Automatic detection of cameras connected online.
- ▶ Ethernet configuration with fixed IP or automatically via DHCP.
- ▶ 7 processing tools: pattern, contrast, blob/counter, measurement, presence, logic and colour.
- ▶ Slot system to enable the change of working mode in autonomous mode.
- ▶ Selection of the active job at camera start-up.
- ▶ Secure access system by means of three user roles: administrator, designer and operator.
- ▶ General camera settings: sensor settings, focus, shutter release and lighting mode.
- ▶ Simple, intuitive configuration.
- ▶ Capture of images to validate work.
- ▶ Focus Assistant that automatically adjusts to optimal camera level.
- ▶ Tool to configure digital and virtual outputs.
- ▶ Checking work with live camera images.
- ▶ Creation of jobs in Emulator mode. Enables the loading of images to create a job without any need for an online camera. This job can be subsequently adapted to a camera by using the latest settings, image and outputs on the plant.

Software designed for easy and comfortable inspection work



Minimum PC requirements

Windows 7	
Processor	1 GHz (32 bit - 64 bit) processor
Memory	1 GB RAM (32 bit) or 2 GB RAM (64 bit)
Graphics Card	Support for DX9 graphics with 128 MB memory (for Aero interface)
Interface	100BASE-TX or higher
Installation space	500 MB free hard drive space
Software requirements	.NET Framework 4.5 or later
Windows 8	
Processor	1 GHz or faster processor that is PAE, NX and SSE2 compatible
Memory	1 GB RAM (32 bit) or 2 GB RAM (64 bit)
Graphics Card	Microsoft DirectX 9 graphics device with WDDM controller
Interface	100BASE-TX or higher
Installation space	500 MB free hard drive space
Software requirements	.NET Framework 4.5 or later
Windows 10	
Processor	1 GHz or faster processor
Memory	1 GB RAM (32 bit) or 2 GB RAM (64 bit)
Graphics Card	DirectX 9 or later with WDDM 1.0 controller
Interface	100BASE-TX or higher
Installation space	500 MB free hard drive space
Software requirements	.NET Framework 4.5 or later

WORK FLOW

DESIGNED FOR A CONSTANTLY EFFECTIVE PRODUCTION PROCESS

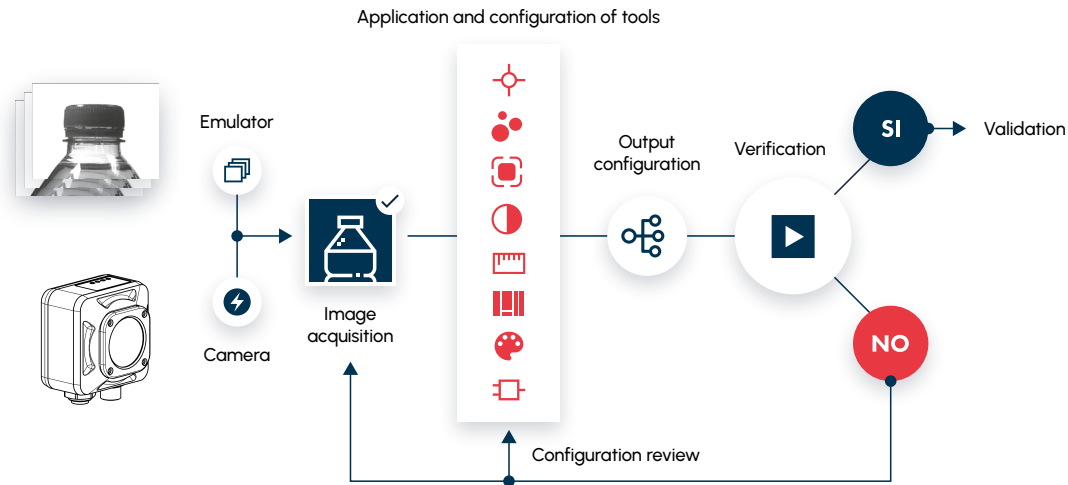

- Tool panel and configuration flow
- Open job tabs
- Job actions
 - ▶ Job validation
 - ▶ Save job
- Configuration panel for the settings of different tools and flows
- Controls on the inspection screen
- Output console
- Image capture

WORK TOOLS

CONDUCT CHECKING TASKS QUICKLY AND EFFICIENTLY

The software enables work to be done together with several tools.



Pattern

Looks for a given pattern via object contours or outline and can be used to position the other tools.



Blob/counter

Quantifies the number of blobs, areas with the same intensity level.



Presence

Determines the presence or absence of an object or edge depending on the selected intensity range.



Contrast

Measures the difference between bright and dark areas inside a region.



Measurement

Checks a distance or angle inside a region.



Codes

Tool for reading, locating barcodes and 2D codes and their angle.



Logic

Evaluates a given logical condition to compose a complex output with the results of other tools.



Colour

Colour is an important feature to detect differences and defects between objects in the production process, such as, for example, in the printing of colours and labels.

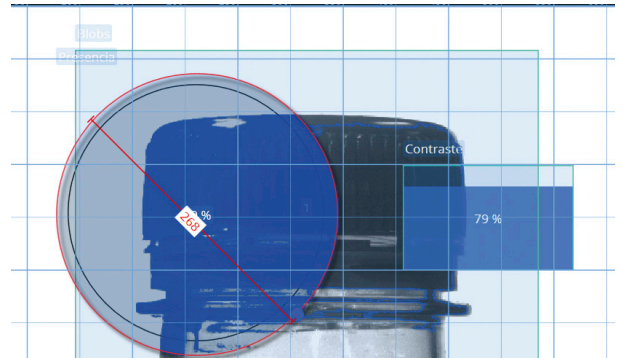

The interface provides constant important information on the active tools. It will be visually in control of the process at all times.

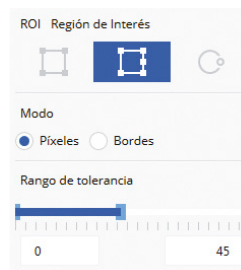

The options for each tool will provide you with the control required for efficient configuration to ensure the checking process.

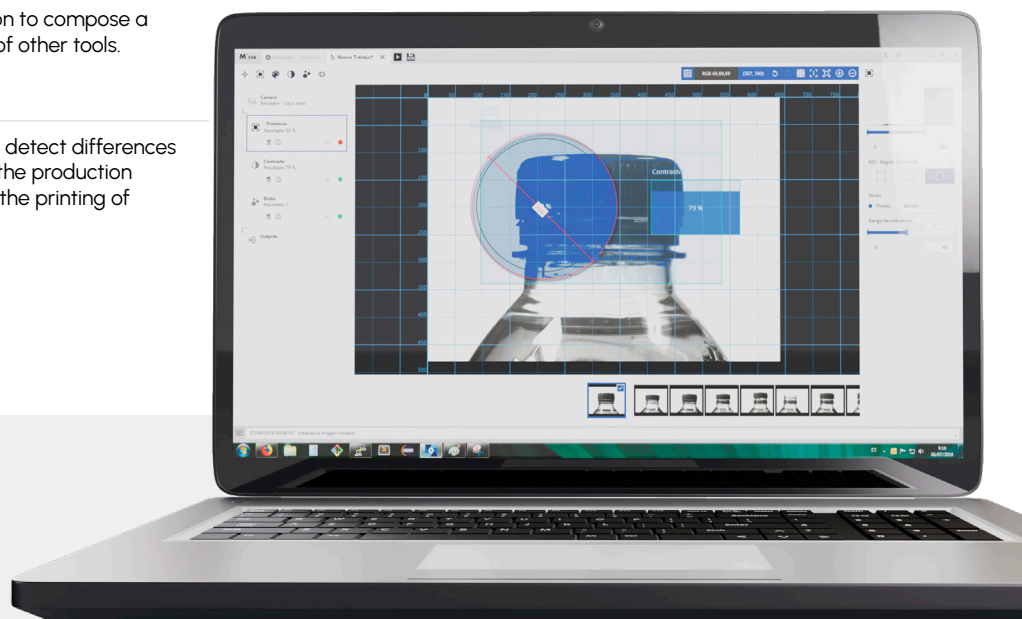

New inspection tools

Measuring tool

Tool to measure the distance or angle between two lines and to calculate the diameter of circles.

Polarity adjustment

It has a specific polarity setting to adjust the detection of lines of interest.

Detection modes

Edges: Centre to centre (px)

Measures the distance between the centre of the two detected lines.

Edges: Perpendicular distance (px)

Measures the perpendicular distance between the right and left line, taking the centre of the right one as a reference.

Edges: Angle (°)

Measures the relative angle between the two detected lines, taking the right line as a reference.

Edges: Angle to origin (°)

Measures the relative angle between the right and left line that marks the end of the region of interest (ROI).

Circle diameter (px)

Measures the diameter of the biggest detected circle. If you adjust the threshold you get circles with smaller diameters than the circle with the biggest one.

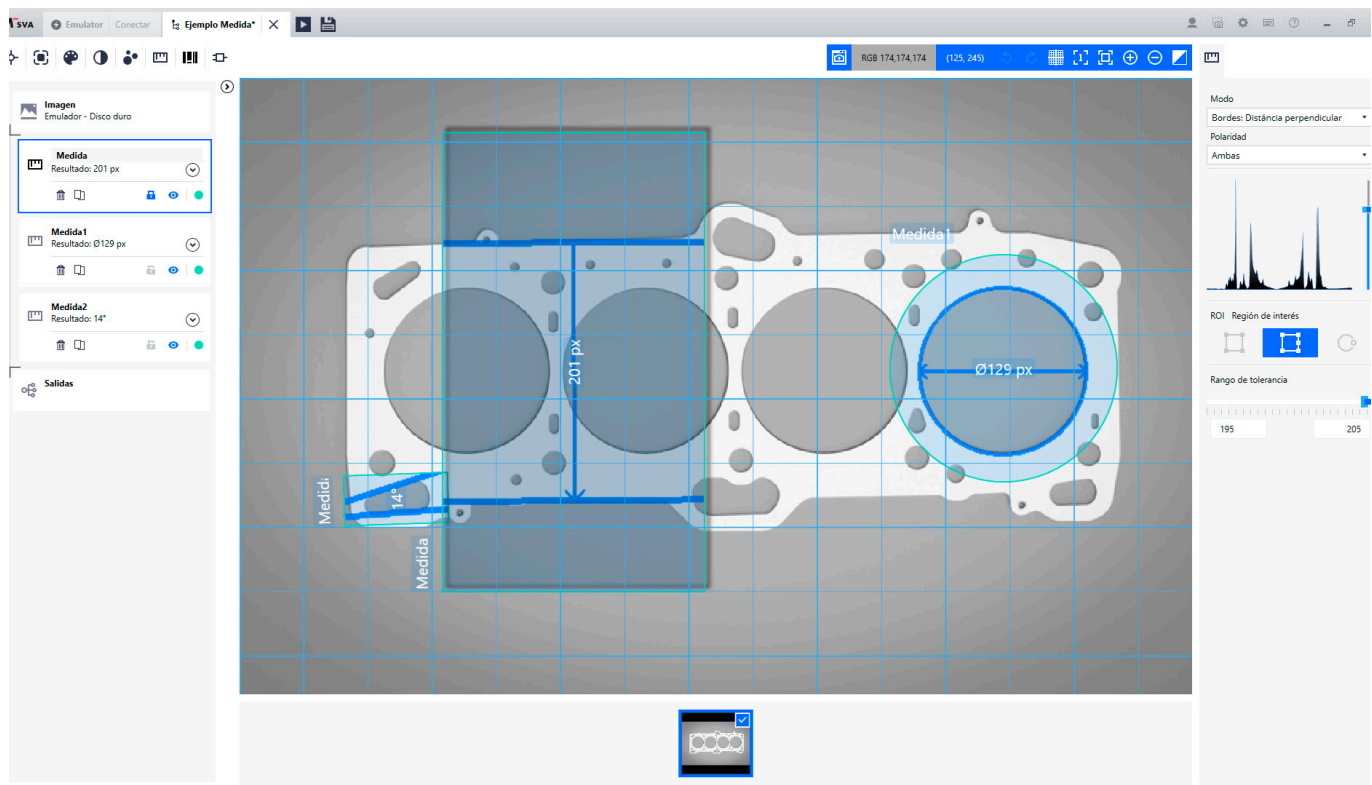

Code tool

Tool for reading, locating barcodes and 2D codes and their angle.

Locating by AI

Considerably reduces decoding time.

It activates barcode location using artificial intelligence to strictly limit the area to be decoded to that which surrounds the detected code.

Settings

- ▶ Expected text
- ▶ Text comparison to check that the pattern entered by the user and the code's decoded text match.

Timeout

Decoding time limiter. If decoding is not done in the time set by the user, the reading operation is aborted.

- ▶ QR
- ▶ Datamatrix
- ▶ UPC-A
- ▶ UPC-E
- ▶ Code-39
- ▶ Code-128
- ▶ EAN-8
- ▶ EAN-13

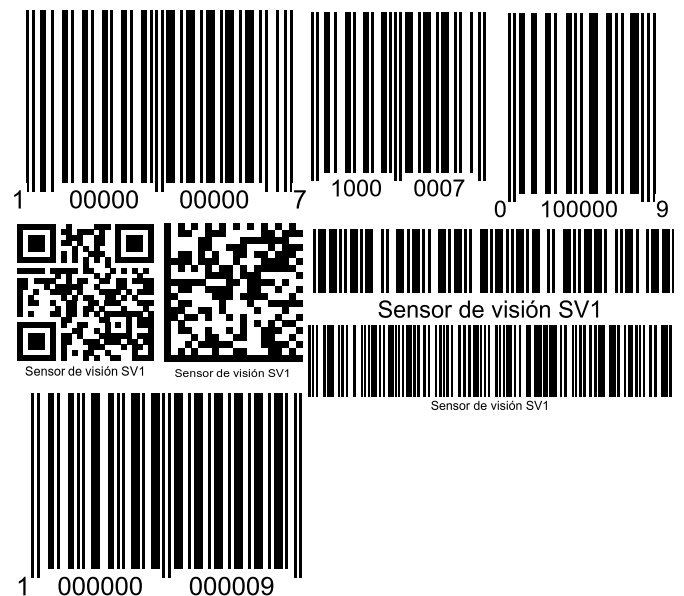



THE IMPORTANCE OF LIGHT IN VISION PROJECTS

To a great extent, the success of any vision project relies on the lighting system chosen. This is a key factor.

Images captured by the sensors depend on optimum object lighting. Light angle and direction are key determinants.

The main tasks of lighting are to:

- ▶ Homogenise ambient luminance.
- ▶ Adjust lighting to the aspects that seek to highlight the object. Optimise the contrast, brightness and control the reflections caused.
- ▶ Simplify subsequent image processing and save processing time by sensor software to enhance acquisition and evaluation times.

Certain general considerations should be taken into account when designing a vision project:

- ▶ Ambient conditions
- ▶ Use of monochrome or colour
- ▶ Inspection speed
- ▶ Field of vision to be lit
- ▶ Properties of the object's materials, if it causes reflection, etc.
- ▶ What characteristic is being sought in the object
- ▶ Types of light sources and characteristics such as the colour

By combining the different types of lighting with various lighting techniques we can find the most efficient solution for the inspection and checking process.

There are several types of lighting for vision, each of which suits different uses and lighting conditions. The following are some of the most common types of lighting:

It is important to select a type of lighting that suits the use to which the vision sensor is to be put as this can affect image quality and the accuracy of inspection results.

Types of lighting

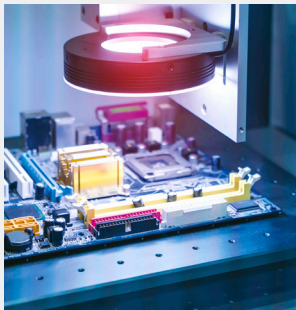

Bar lighting

Bar lighting provides a strip of light on the object or along the object's edge to achieve uniform lighting in the region of interest. It can be combined with other bar lights to cover the entire object from all directions. Depending on the light and camera angle, bar lighting may improve or worsen

specular reflection. It is used to add contrast to matt surfaces like paper or cardboard, to define edges and to highlight surface features.



Ring lighting

Ring lighting is a circle or ring of bright, intense light that provides shadow-free lighting and good image contrast. This type of lighting is frequently used on account of its versatility. It is often used together with the dark field technique.

Light diffusers

These are used to spread or scatter the light, thereby achieving a less intense light. It may take the form of an accessory or be built into the light source.

Colour filters

Colour filters create contrast to lighten or darken object properties. Like colours are lightened (i.e., red light makes red features brighter), whereas opposite colour filters darken (i.e., red light darkens green features).



UV

Ultraviolet lighting is ideal to inspect surfaces. This type of lighting can be used for numerous purposes because it makes the target material much brighter.

Transparent glues on bottoms, adhesive pearls, sealing compounds, etc., are all UV-active. It can also be used to inspect PCBs and weld joints. Flaws, scrapes and other characteristics are made clearly visible. UV-active inks and dyes used for marking and identification. Types of printed letters and security characteristics.



Infrared lighting (IR)

Infrared lighting can penetrate deeply into materials and produces less reflection on surfaces than visible lighting. Because it cannot be seen by the naked eye, infrared lighting is ideal for use when visible light would be uncomfortable.

IR can help reduce colours, glare and reflections when being used for particular purposes that require image filters. Certain flaws can be identified by IR that would not be picked up by visible light, e.g., detecting damaged food items.

In addition to infrared light being able to penetrate surfaces, it can also be used to lessen the effects of colour on surfaces and reduce the effect of bad ambient lighting, artificial lighting or indoor lighting.

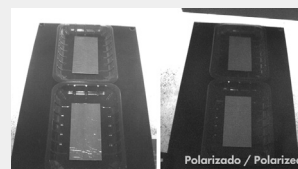

Polarised lighting

Polarizers are filters placed in front of the lights and camera lens at a 90-degree offset. They are used for processing images to reduce glare and hot spots and enhance contrast so the entire object can be recognised.

Lighting techniques

Different lighting techniques seek to get a more accurate image of the object to achieve the best possible vision sensor interpretation.

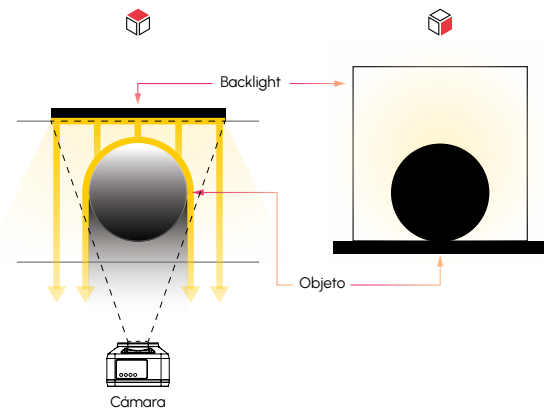

Back Lighting

This technique consists in lighting up the object from behind, in which case the object is positioned between the light source and camera thereby highlighting the object's contours or outline. Lighting must be evenly distributed on the entire surface to highlight the silhouette created.

Applications: Ideal for inspecting objects by contrast. It makes it possible to detect the presence or absence of holes and gaps. It can also be used on translucent or transparent materials to detect flaws such as stains, bubbles, scrapes, cracks, etc.

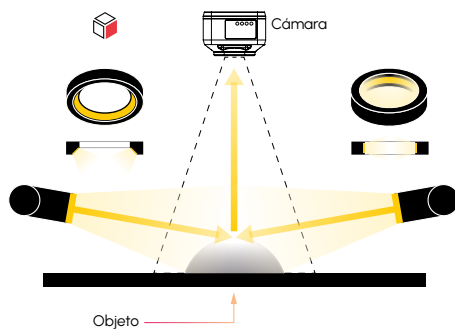

Dark Field

Light is applied very lowly, and at a shallow angle to the object. Surface defects are highlighted and reflected towards the camera while the rest of the surface remains in the dark.

Applications: This is particularly suitable for shiny and reflective surfaces as it highlights areas in relief. It is recommended for reading barcodes, laser or die type cutting on low contrast surfaces (grey on grey, metal on metal) and shiny or polished metal parts.

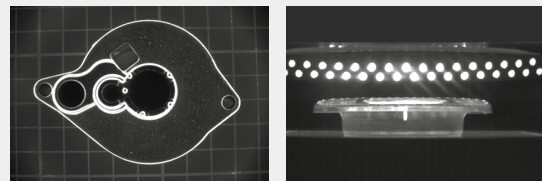

Dome Lighting

This technique consists of scattering light in all directions from inside a dome, thereby eliminating shades and glares, softening textures and minimising the impact of reliefs that may be found on the object under inspection.

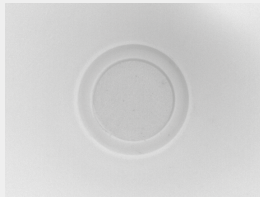

It is also called cloudy-day lighting on account of not causing shadows on the object.

Applications: It is ideal for inspecting shiny or metal surfaces.

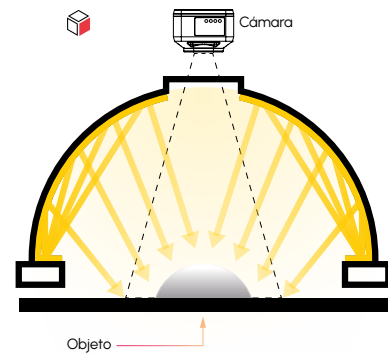

Side lighting

This involves the camera looking at the object when the object is lit from the side. The angle of inclination of the light source is determined by the degree to which you want to highlight reliefs.



Applications: It is used to highlight edges, scratches and cracks in a particular direction.

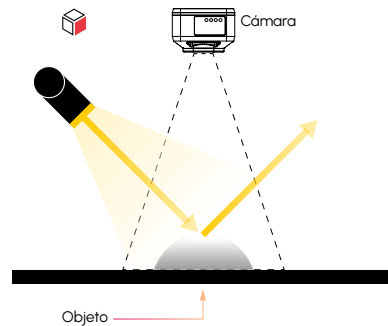

Coaxial (On-Axis) Lighting

Light is transmitted laterally, perpendicular to the camera and reflected by a semi-transparent mirror placed at a 90-degree angle to the object. This technique serves to highlight specular surfaces that are perpendicular to the camera and will darken those that are at an angle to it. It reduces shadowing and has very little glare.



Applications: It is particularly suitable for inspecting flat, reflective surfaces, reflective labels and print on metal.

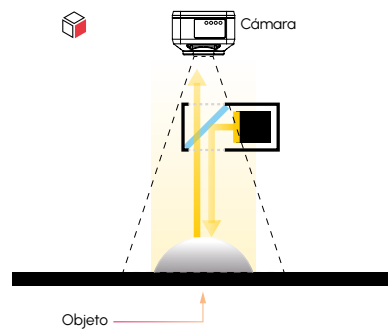

LED LIGHTING SYSTEMS FOR MACHINES AND INDUSTRIAL SIGNALLING



LMD Series

White lighting for machines



LMD/S Series

Signalling



LMD/SD Series

DOMO



LMD/C Series

Combined white light and RG lighting



LED lighting systems are widely used on machines and for signalling on account of their energy efficiency, long service life and cost-effectiveness and low cost in comparison to other lighting technologies.

LED lighting is used on machines to light up work areas, provide visibility in dark spaces and enhance workplace safety. It is also used to light control panels and display devices.

It is used as signalling and signage to provide a clear and visible signal/sign, even in poor lighting

conditions. LEDs can produce bright and clear colours, which makes them ideal for emergency signalling, such as warning and status indication lights.

LED lighting also opens the door to a wide range of design options and can be adapted to different lighting needs and requirements. Moreover, LED systems produce less heat and as well as being mercury free. They also do not contain any other hazardous chemicals, which makes them both safer and more environment friendly.

Main advantages

LED lighting systems are an excellent option for machines and signalling on account of their numerous benefits, which include:

Energy efficiency: LEDs use significantly less power than traditional lights, which means energy savings and a reduced carbon footprint.

Long service life: LEDs have a much longer service life than traditional lights, thus they do not need to be replaced so often, which saves on maintenance costs.

Durability: LEDs are more durable than traditional lights and can withstand vibrations and knocks, which makes them ideal for signalling and industrial environments.

Flexibility: They are highly customisable and can be fit-for-purpose designed. For example, they can be designed to provide spot lighting or to light up big spaces.

Low voltage: LEDs work with much lower voltages than other light sources, thereby making them safer and easier to integrate into machine systems.

Versatility: LED lighting systems can be used in a variety of applications, including machine lighting, signalling, emergency lighting and security lighting.

When choosing a lighting system for your machine, it is important to consider factors such as: the amount of light needed; the desired colour temperature; and the shape and size of the LED to be used.

LED lighting is an excellent option for machines and signalling on account of its energy efficiency, long service life, durability, flexibility and versatility.

Applications

LED lighting systems are widely used on machinery and for signalling on account of their energy efficiency, long service life and capacity to provide bright and clear lighting. The following are just some of the commonplace applications of LED lighting systems for machines and signalling:

Work lighting: They are often used on machines to provide a bright and clear light to enable workers to better see what they are doing. These lights can be fitted to the machine or mounted on independent supports.

Safety lighting: They are also used for safety signalling to alert workers to potential dangers. For example, LED lights can be used in hazardous zones as a warning to workers to be extra careful.

Control panel lighting: LED lights are used on control panels to provide bright and clear lighting so workers can better see controls and settings.

Generally speaking, LED lighting systems are a common option to light machines and for signalling on account of their energy efficiency, long service life and capacity to provide bright and clear lighting in a variety of applications.

LMD Series

White lighting for machines



IP67 rated lights are dust resistant and can withstand being temporarily immersed in water, which makes them the ideal choice for a lot of industrial lighting applications, including machine lighting and machine tool settings in which cutting oils and detergents can put light resistance to the test.

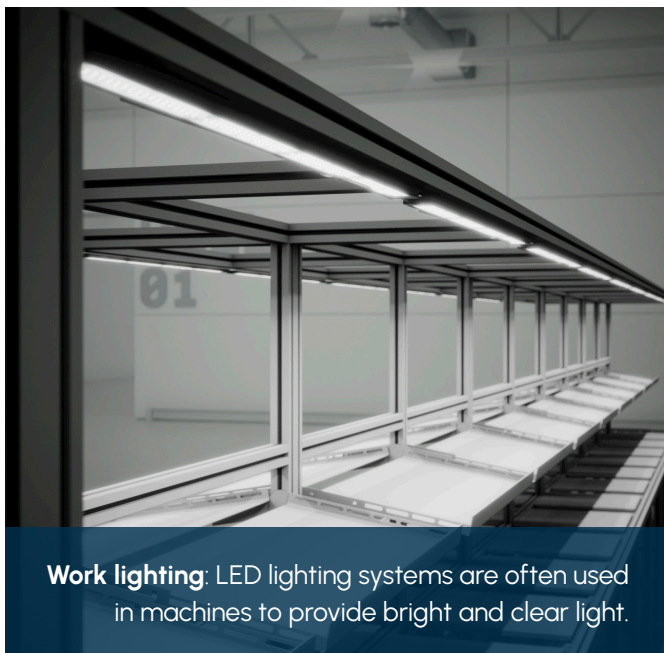

Work lighting: LED lighting systems are often used in machines to provide bright and clear light.

High performance and bright LED lighting for optimum work area visibility

Uniform area lighting

IP67 protection rating

Flash trigger via external trigger input

Luminous intensity adjustment via PWM signal

Quality standards

DIN EN 12464-1
EN 12464-1

Technical specifications

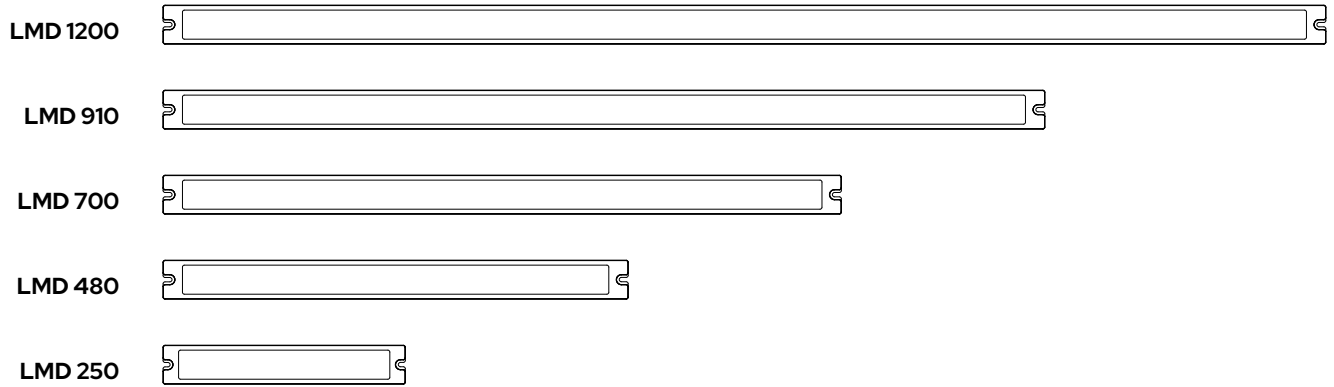

Service life	54.000h
Emitted beam angle	120°
White temperature	5000 K
Protection rating	IP67
Material	Black anodised aluminium
Window material	Transparent PU. Withstands UV exposure.
Connections	35 cm PUR cable with 3 pin, M12 connector

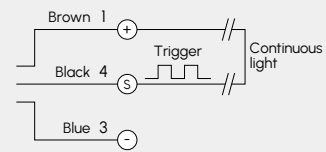

Reference	Lighted area	Luminous flux	Luminous intensity	Power	Connections	Weight
LMD 250CK03	30 x 220 mm	1100 lm	1.8 klx (0.5 m / 100%) 0.53 klx (1.0 m / 100%)	9.6 W (24 V)	35 cm PUR cable with 3 pin, M12 connector	210 g
LMD 480CK03	30 x 440 mm	2200 lm	3.2 klx (0.5 m / 100%) 1.0 klx (1.0 m / 100%)	19.2 W (24 V)	35 cm PUR cable with 3 pin, M12 connector	390 g
LMD 480CK03M8	30 x 440 mm	2200 lm	3.2 klx (0.5 m / 100%) 1.0 klx (1.0 m / 100%)	19.2 W (24 V)	35 cm PUR cable with 3 pin, M8 connector	390 g
LMD 700CK03	30 x 660 mm	3300 lm	3.9 klx (0.5 m / 100%) 1.3 klx (1.0 m / 100%)	28.8 W (24 V)	35 cm PUR cable with 3 pin, M12 connector	550 g
LMD 910CK03	30 x 870 mm	4400 lm	4.4 klx (0.5 m / 100%) 1.6 klx (1.0 m / 100%)	38.4 W (24 V)	35 cm PUR cable with 3 pin, M12 connector	700 g
LMD 1200CK03	30 x 1000 mm	5500 lm	4 klx (0.5 m / 100%) 1.6 klx (1.0 m / 100%)	48 W (24 V)	35 cm PUR cable with 3 pin, M12 connector	900 g

	E_{max} (lx)	E_{med} (lx)	E_{min} (lx)	\varnothing (m)
0,5m	1626	466	123	1.6
1m	407	116	31	3.2
1,5m	181	52	14	4.8
2m	102	29	8	6.4

* Reference measurements for the LMD 250 model

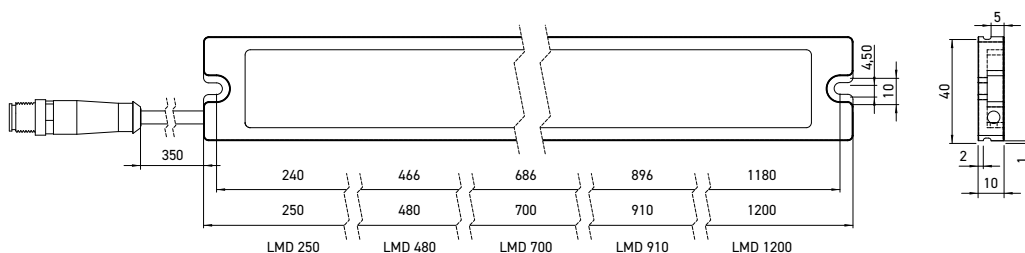

LMD/S Series



Signalling

LED lighting systems are used in signalling to provide a clear and visible signal, even in poor lighting conditions.

LEDs can produce bright and clear colours, which makes them ideal for emergency signalling, such as warning and operating status indication lights, both in machines as well as for access control purposes.

High performance and bright LED lighting for optimum visibility

Uniform area lighting

IP67 protection rating

Continuous lighting

3 separate operating modes for each colour

Trigger controlled Flash

PWM light adjustment

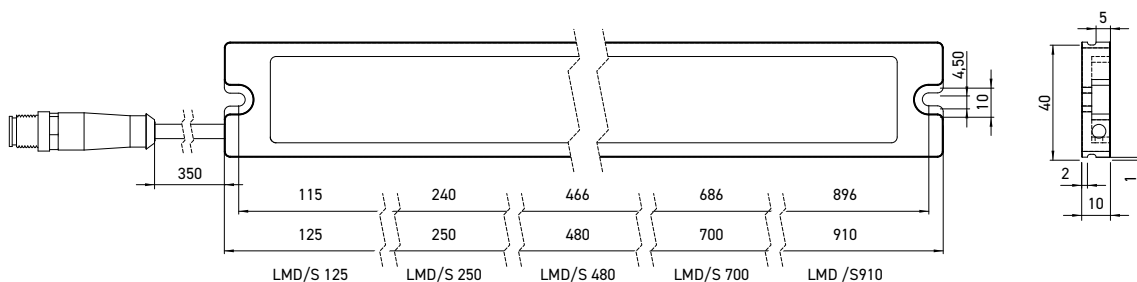

Technical specifications

LMD/S 910

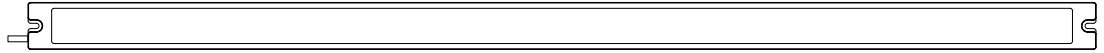

LMD/S 700

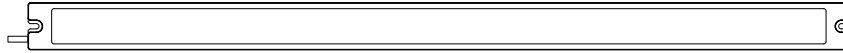

LMD/S 480

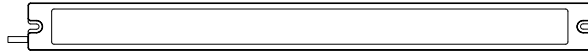

LMD/S 250

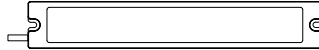

LMD/S 125

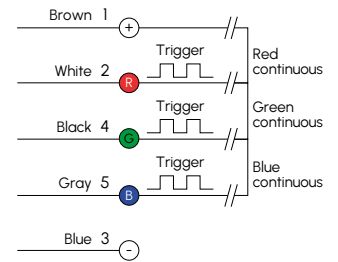
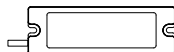

Reference	LMD/S RGB 125CK03	LMD/S RGB 250CK03	LMD/S RGB 480CK03	LMD/S RGB 700CK03	LMD/S RGB 910CK03
Lighted area	30 x 95 mm	30 x 220 mm	30 x 440 mm	30 x 660 mm	30 x 870 mm
Service life	50.000h	50.000h	50.000h	50.000h	50.000h
Colour	Red (625 nm) Green (525 nm) Blue (457 nm)	Red (625 nm) Green (525 nm) Blue (457 nm)	Red (625 nm) Green (525 nm) Blue (457 nm)	Red (625 nm) Green (525 nm) Blue (457 nm)	Red (625 nm) Green (525 nm) Blue (457 nm)
Beam angle	120°	120°	120°	120°	120°
Intensity adjustment	Yes, by PWM	Yes, by PWM	Yes, by PWM	Yes, by PWM	Yes, by PWM
Protection rating	IP67	IP67	IP67	IP67	IP67
Material	Black anodised aluminium	Black anodised aluminium	Black anodised aluminium	Black anodised aluminium	Black anodised aluminium
Window material	Transparent PU. Withstands UV exposure.	Transparent PU. Withstands UV exposure.	Transparent PU. Withstands UV exposure.	Transparent PU. Withstands UV exposure.	Transparent PU. Withstands UV exposure.
Connections	35 cm PUR cable with 5 pin. M12 connector	35 cm PUR cable with 5 pin. M12 connector	35 cm PUR cable with 5 pin. M12 connector	35 cm PUR cable with 5 pin. M12 connector	35 cm PUR cable with 5 pin. M12 connector
Weight	115 g	210 g	390 g	550 g	700 g



LMD/SD Series DOMO LED



High performance **DOMO** LED for optimum visibility

360° uniform lighting in the lighted area

IP67 protection rating

Immune to **EMI and RFI** interference

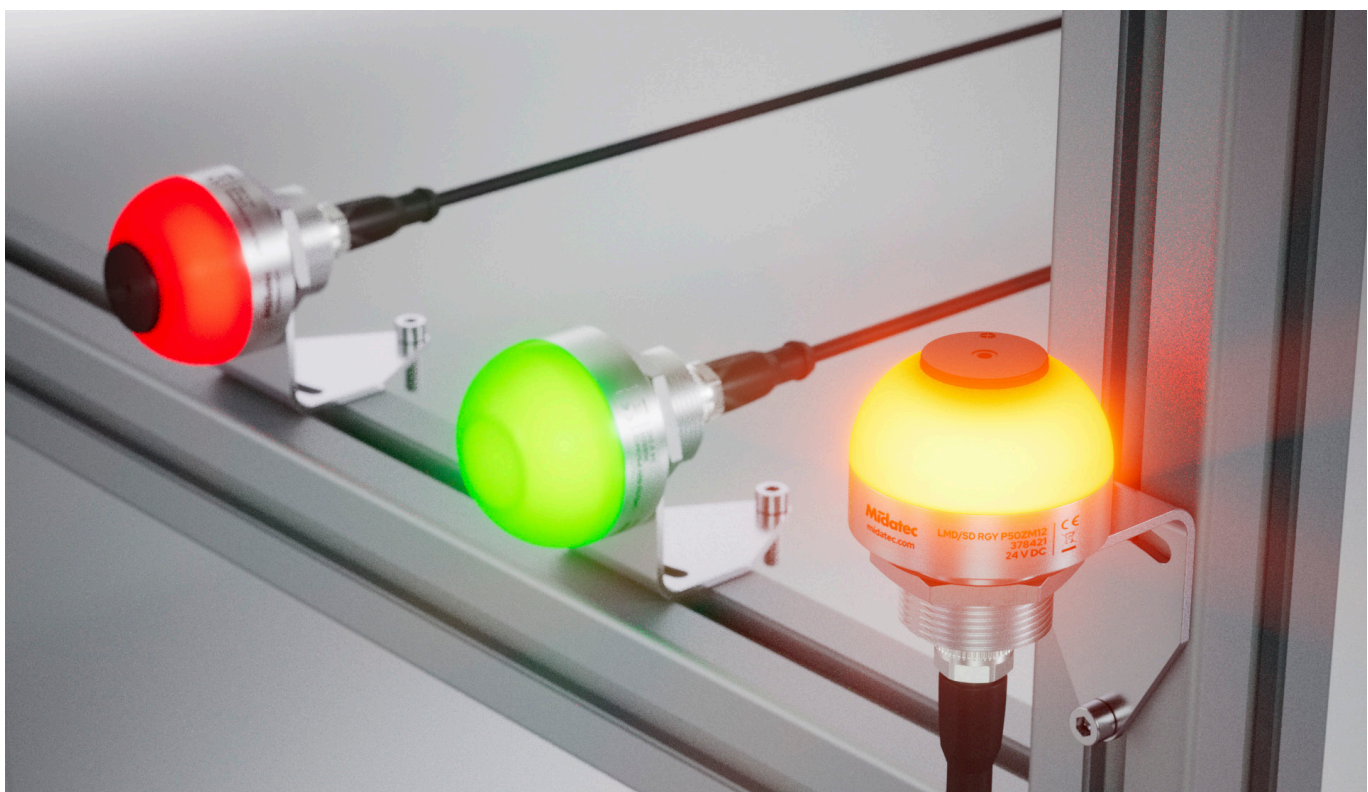

LMD/SD 50

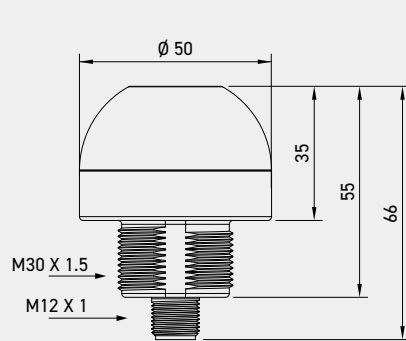

LMD/SD 50Z Model with sound signal

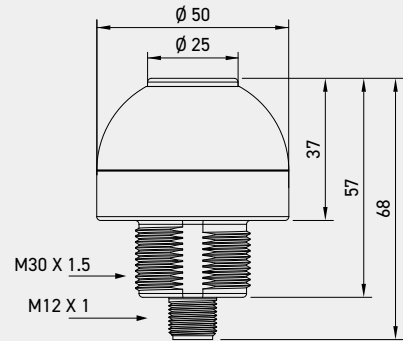

Reference	LMD/SD RGY P50M12	LMD/SD RGY P50ZM12
Lighted area	30 x 220 mm	30 x 220 mm
Colour	Red (625 nm), Green (525 nm) and Amber (575 nm)	Red (625 nm), Green (525 nm) and Amber (575 nm)
Emitted beam angle	360°	360°
Luminous intensity adjustment	No	No
Service life	50.000h	50.000h
Sound signal	-	Yes, continuous.
Sound power	-	75 dB
Flicker frequency	-	3 kHz ± 500 Hz
Supply voltage	24 Vdc ± 5%, (class 2 supply)	24 Vdc ± 5%, (class 2 supply)
Max. current	R - 40 mA G - 30 mA Y - 70 mA	R - 40 mA G - 30 mA Y - 70 mA
Trigger input	3 separate inputs, one per colour	4 separate inputs, one per colour + buzzer
High level trigger input	22.8 ... 25.2 V	22.8 ... 25.2 V
Reverse polarity protection	Yes	Yes
Ambient operating temperature	-20 ... +40 °C	-20 ... +40 °C
Protection rating	IP67	IP50
Protection class	III, low voltage operation	III, low voltage operation
DIN EN 62471 risk group	Free group	Free group
Housing material	Silver anodised aluminium	Silver anodised aluminium
Window material	Translucent PC (Polycarbonate)	Translucent PC (Polycarbonate)
Connections	5-pin, M12 connector	5-pin, M12 connector

Connection diagram

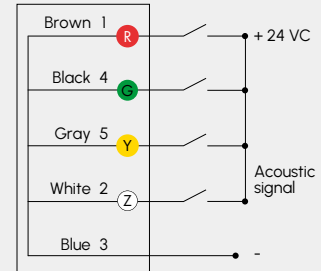
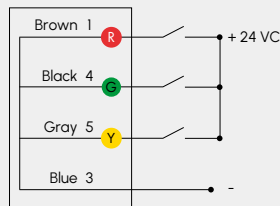

LMD/C Series

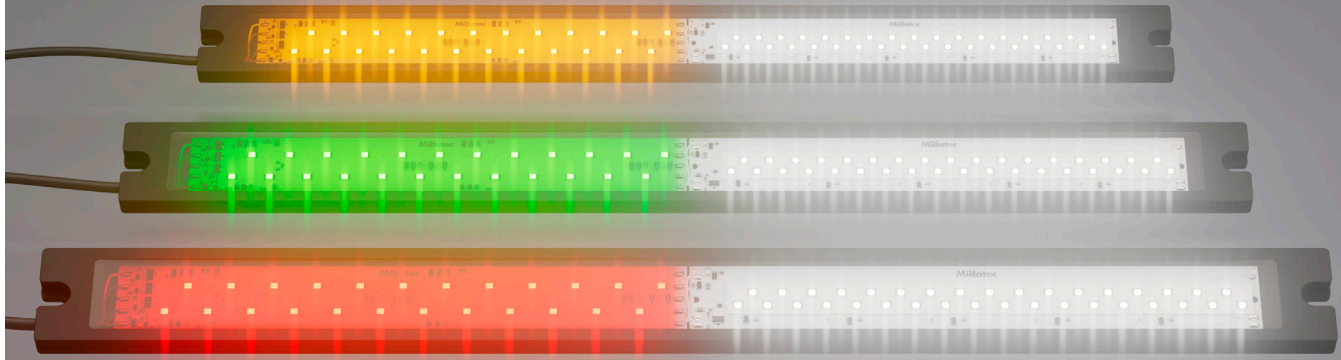
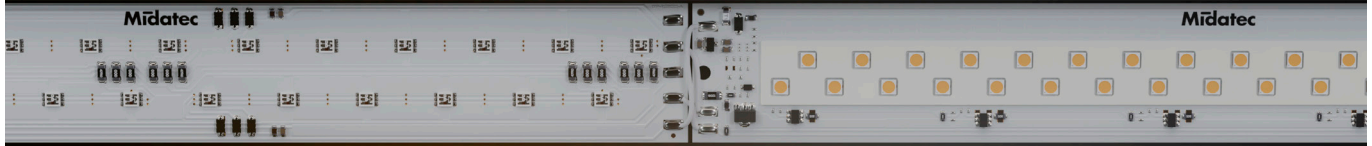

Combined lighting

The LMD/C series combines white light and a red, green or amber configured element to indicate operating statuses.

Highly intense and efficient LED lighting for optimum work area visibility

Uniform area lighting

Combination of high intensity LED lighting with signalling

White lighting

Colour lighting. Red, Green and Amber (achieved by activating red and green simultaneously)

IP67 protection rating

3 operating modes:

Continuous lighting

Trigger controlled Flash

PWM light adjustment

Technical specifications

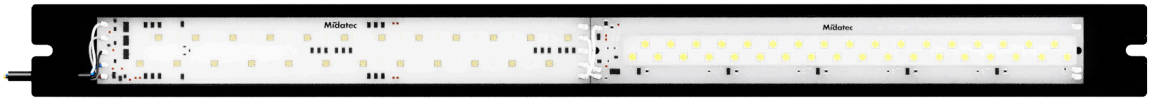

Reference	LMD/C RGW 480CK03
Lighted area	30 x 440 mm
Service life	50.000h
Colour	White (5000 K) Red (625 nm) Green (525 nm)
Emitted beam angle	120°
Luminous flux	2200 lm
Colour rendering index (CRI)	80
Luminous intensity	3.2 klx (0.5 m / 100%) 1.0 klx (1.0 m / 100%)
Luminous intensity adjustment	Yes, by PWM
Supply voltage	24 Vdc ± 5% (class 2 supply)
Trigger input	3 separate inputs, one per colour
Low level trigger input	0 ... 3.5 V
High level trigger input	8.0 ... 25.2 V
Shock and vibration resistance	10 ... 55 Hz / 1.0 mm / 30 g
Reverse polarity protection	Yes

Connection trigger delay	50 us
Disconnection trigger delay	50 us
Ambient operating temperature	-20 ... +40 °C
Protection rating	1, IP67
Protection class	III, low voltage operation
DIN EN 62471 risk group	Free group
Housing material	Black anodised aluminium
Window material	Transparent PU. Withstands UV exposure.
Connection cable	Ø4.6 mm, black PUR
Connection type	Straight cable + connector
Connector	M12
Pins	5
Cable material	PUR
Cable length (m)	0.35
Cable diameter (mm)	4.6
Weight	390 g

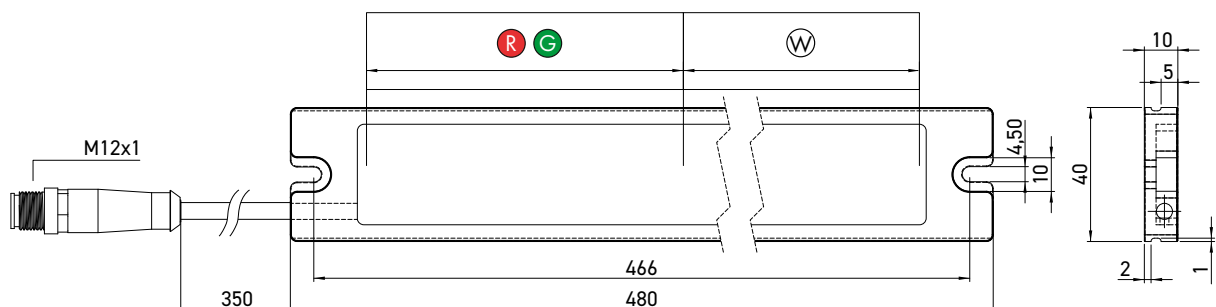
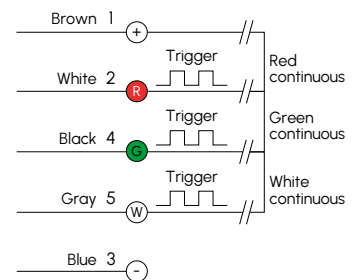

Accessories

TD001

This sensor tester is a multi-purpose accessory that provides functions beyond those of a simple tester, thus making it an extremely useful tool for jobs, regardless of the circumstances or environmental conditions involved.



Three detection modes available

- ▶ Digital (D)
- ▶ Voltage (V)
- ▶ Current (I)

Digital input, automatic detection

- ▶ PNP, NPN

15-digit CAD precision

Power display

Battery charge level indicator

Standby mode

Save energy using this mode, which keeps the device on standby by turning off the power and recovering it by simply pressing the operating Mode or Teach-In button.







Teach-In function

Torch function

It comes with an extremely useful LED torch for poor working visibility conditions.

Battery bank function

This also offers a portable device charging function by connecting it through the output

	Torch function
	Brown terminal output voltage 19 V ~ 24 V USB output voltage 4.8 V - 5 V
	Operating temperature -10 ... 45 °C
	USB Output
	15-digit CAD precision
	Weight: 200 g

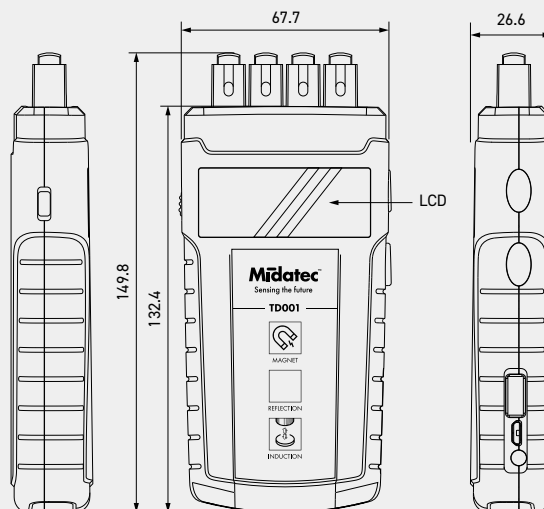

Brackets

Sensor mounting brackets

Vertical bracket

AD010-V

Stainless steel

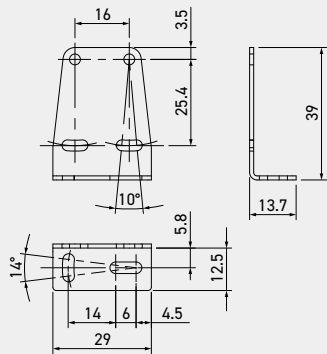
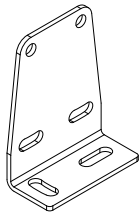

Side bracket

AD010-H

Stainless steel

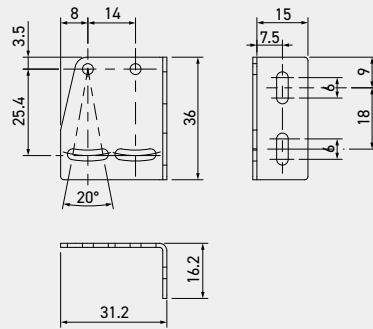
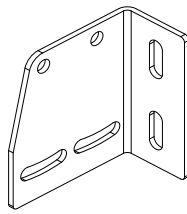

Bracket for M18 barrel housing

SDI 18

Barrel housing Ø18 mm. Pitch 30mm
Transparent PA and PBT

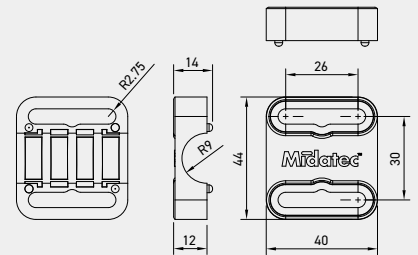

Bracket for M8 barrel housing



Reference	Diameter	Configuration
SDI 8s	8 mm	No stop
SDI 8t	8 mm	With stop

Bracket for M12 barrel housing



Reference	Diameter	Configuration
SDI 12s	12 mm	No stop
SDI 12t	12 mm	With stop

Bracket for M30 barrel housing



Reference	Diameter	Configuration
SDI 30s	30 mm	No stop
SDI 30t	308 mm	With stop

Vision sensor bracket

AV001

Material: Aluminium 6082. Finish: Anodised black. Weight: 20.24 g

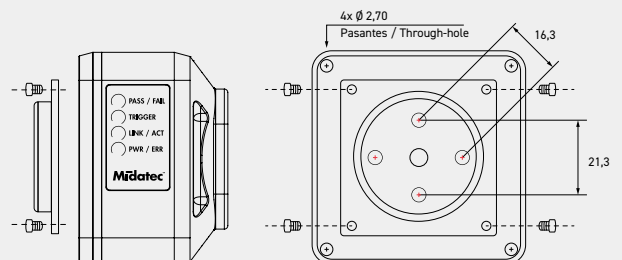

Ultrasonic accessories

Deflectors

AD001 - M18

Sound deflector for sensor with M18 threaded bushing.
 Exploration extension: ≤ 0.35 m
 Material: Stain. Steel
 Weight: 40 g

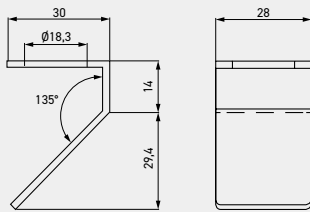

AD002 - M30

Sound deflector for sensor with M30 threaded bushing.
 Exploration extension: ≤ 1.3 m.
 Material: Stain. Steel
 Weight: 100 g

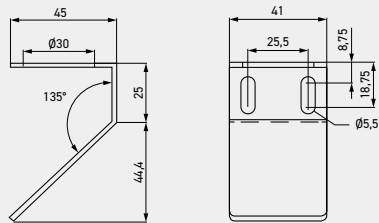

AD006 - M18

90° deflector with M18 threaded bushing

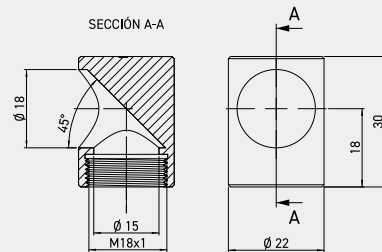

Soundpipes for ultrasonic sensors

AD003 - Soundpipe

MidC 007/015/024
 ABB plastic soundpipe. Weight: 1 g.

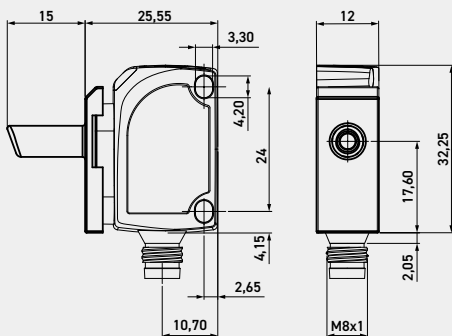

AD004 - MidS+

M18. Material: Stain. Steel Weight: 28.4 g

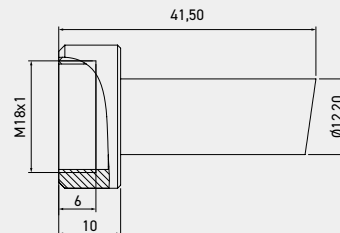

Lighting

Brackets for LMD series

AD007-25 - Ø25-7 mm

AD007-40 - Ø40-8 mm

Easy to install, adjustable brackets with no need for drilling or bolting

Set of 2 x high power magnets with M4 thread, 2 x M4x10 Allen screws, 2 washers.

AD008

The set comprises a short arm (2x2), a long arm (2x1) and the necessary attachment material plus M4 nuts and bolts

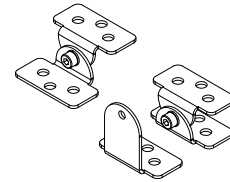
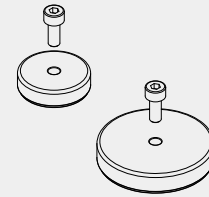

LMD series Diffusers

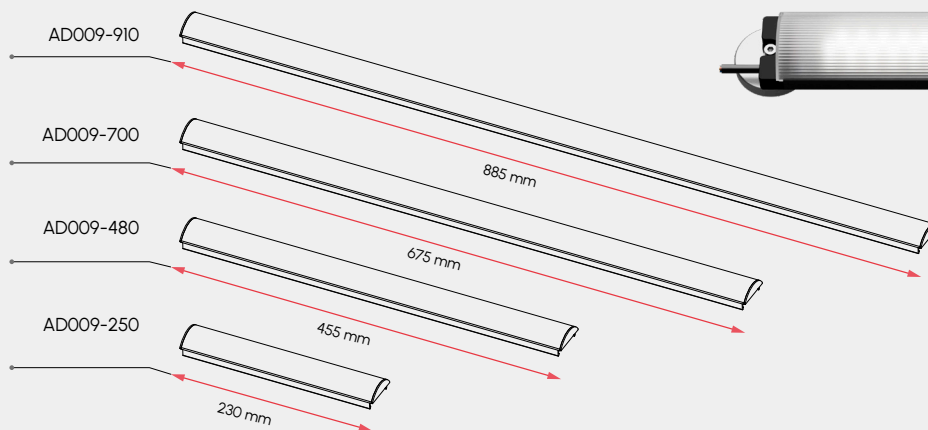

Accessory to avoid glaring in the working zone without loss of light quality thanks to the approximately 120° to 180° angle of dispersion.

Quick and easy mounting. Made of high-resistant polycarbonate.

LMD/SD 50 - 50Z series bracket





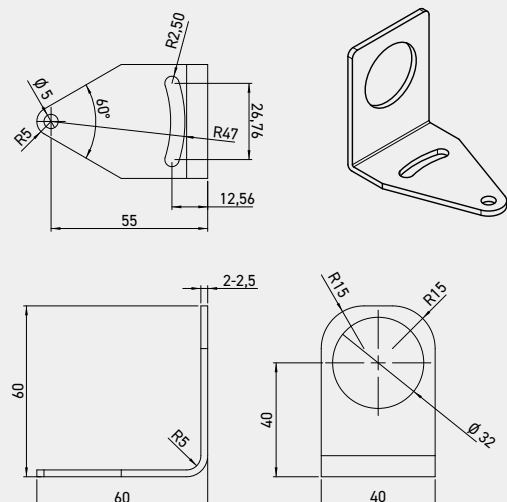

AD015

Bracket for LMD/SD Ø50 with M30 attachments

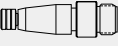
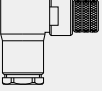

Connectors

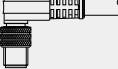
M8 connectors

	Reference	Connection type	Gender	Connector	Pins	Wires	Cable length (m)	Cable material	
	CT M8/3 M12 HM	M8-M12 adapter	Female-Male	M8	3	3			
	CT M8/4 M12 HM	M8-M12 adapter	Female-Male	M8	4	4			
	CT M8/3 HCS	Jack connector	Female-Angle	M8	3	3			
	CT M8/4 HCS	Jack connector	Female-Angle	M8	4	4			
	CT M8/4 HRS	Jack connector	Female-Straight	M8	4	4			
	CT M8/4 HRT	Jack connector	Female-Straight	M8	4	4			
	CT M8/3 HRT	Jack connector	Female-Straight	M8	3	3			
	CT M8/4 MCS	Jack connector	Male-Elbow	M8	4	4			
	CT M8/3 MCS	Jack connector	Male-Elbow	M8	3	3			
	CT M8/4 MRT	Jack connector	Male-Straight	M8	4	4			
	CT M8/3 MRT	Jack connector	Male-Straight	M8	3	3			
	CT M8/3 TPE5 HC	Thermowelded connector	Female-Angle	M8	3	3	5	WSOR	
	CT M8/3 PUR10 HC	Thermowelded connector	Female-Angle	M8	3	3	10	PUR	
	CT M8/4 PUR5 HC	Thermowelded connector	Female-Angle	M8	4	4	5	PUR	
	CT M8/3 TPE2 HC	Thermowelded connector	Female-Angle	M8	3	3	2	WSOR	
	CT M8/4 PUR2 HC	Thermowelded connector	Female-Angle	M8	4	4	2	PUR	
	CT M8/3 PUR5 HC	Thermowelded connector	Female-Angle	M8	3	3	5	PUR	
	CT M8/4 PUR10 HC	Thermowelded connector	Female-Angle	M8	4	4	10	PUR	
	CT M8/3 PUR2 HC	Thermowelded connector	Female-Angle	M8	3	3	2	PUR	
		CT M8/4 PUR10 HR	Thermowelded connector	Female-Straight	M8	4	4	10	PUR
		CT M8/3 PUR2 HR	Thermowelded connector	Female-Straight	M8	3	3	2	PUR
CT M8/3 TPE5 HR		Thermowelded connector	Female-Straight	M8	3	3	5	WSOR	
CT M8/3 PUR10 HR		Thermowelded connector	Female-Straight	M8	3	3	10	PUR	
CT M8/4 PUR5 HR		Thermowelded connector	Female-Straight	M8	4	4	5	PUR	
CT M8/3 TPE2 HR		Thermowelded connector	Female-Straight	M8	3	3	2	WSOR	
CT M8/4 PUR2 HR		Thermowelded connector	Female-Straight	M8	4	4	2	PUR	
CT M8/3 PUR5 HR	Thermowelded connector	Female-Straight	M8	3	3	5	PUR		

M12 connectors

	Reference	Connection type	Gender	Connector	Pins	Wires	Cable length (m)	Cable material
	CT M12/4D TPE2 MCRJ	Ethernet extension cable	Male-Elbow to RJ45	M12	4	4	2	TPE
	CT M12/4D TPE5 MCRJ	Ethernet extension cable	Male-Elbow to RJ45	M12	4	4	5	TPE
	CT M12/4D TPE10 MCRJ	Ethernet extension cable	Male-Elbow to RJ45	M12	4	4	10	TPE
	CT M12/4D TPE5 MRRJ	Ethernet extension cable	Male-Straight to RJ45	M12	4	4	5	TPE
	CT M12/4D TPE10 MRRJ	Ethernet extension cable	Male-Straight to RJ45	M12	4	4	10	TPE
	CT M12/4D TPE2 MRRJ	Ethernet extension cable	Male-Straight to RJ45	M12	4	4	2	TPE
	CT M12/5 HC7	Jack connector	Female-Angle	M12	5	5		
	CT M12/5 HR7	Jack connector	Female-Straight	M12	5	5		
	CT M12/5 MC7	Jack connector	Male-Elbow	M12	5	5		
	CT M12/4 MC7	Jack connector	Male-Elbow	M12	5	4		
	CT M12/5 MR7	Jack connector	Male-Straight	M12	5	5		
	CT M12/4 MR7	Jack connector	Male-Straight	M12	5	4		
	CT M12/4 TPE5 HC	Thermowelded connector	Female-Angle	M12	5	4	5	WSOR
	CT M12/8 TPE2 HC	Thermowelded connector	Female-Angle	M12	8	8	2	WSOR
	CT M12/12 PUR5 HC	Thermowelded connector	Female-Angle	M12	12	12	5	PUR
	CT M12/4 PUR5 HC LP	Thermowelded connector	Female-Angle	M12	5	4	5	PUR
	CT M12/4 PUR10 HC	Thermowelded connector	Female-Angle	M12	5	4	10	PUR
	CT M12/4 PVC2 HC	Thermowelded connector	Female-Angle	M12	5	4	2	PVC
	CT M12/4 TPE2 HC	Thermowelded connector	Female-Angle	M12	5	4	2	WSOR
	CT M12/8 TPE10 HC	Thermowelded connector	Female-Angle	M12	8	8	10	WSOR
	CT M12/12 PUR10 HC	Thermowelded connector	Female-Angle	M12	12	12	10	PUR
	CT M12/4 PUR5 HC	Thermowelded connector	Female-Angle	M12	5	4	5	PUR
	CT M12/5 TPE5 HC	Thermowelded connector	Female-Angle	M12	5	5	5	TPE
	CT M12/8 TPE5 HC	Thermowelded connector	Female-Angle	M12	8	8	5	WSOR
	CT M12/12 PUR2 HC	Thermowelded connector	Female-Angle	M12	12	12	2	PUR
	CT M12/4 PUR2 HC	Thermowelded connector	Female-Angle	M12	5	4	2	PUR
	CT M12/4 PUR5 HR	Thermowelded connector	Female-Straight	M12	5	4	5	PUR
	CT M12/4 PVC5 HR	Thermowelded connector	Female-Straight	M12	5	4	5	PVC
	CT M12/5 PUR10 HR	Thermowelded connector	Female-Straight	M12	5	5	10	PUR
	CT M12/5 TPE5 HR	Thermowelded connector	Female-Straight	M12	5	5	5	TPE
	CT M12/12 PUR2 HR	Thermowelded connector	Female-Straight	M12	12	12	2	PUR
	CT M12/8 TPE5 HR	Thermowelded connector	Female-Straight	M12	8	8	5	WSOR
	CT M12/4 PUR2 HR	Thermowelded connector	Female-Straight	M12	5	4	2	PUR
	CT M12/5 PUR5 HR	Thermowelded connector	Female-Straight	M12	5	5	5	PUR
	CT M12/4 TPE5 HR	Thermowelded connector	Female-Straight	M12	5	4	5	WSOR
	CT M12/8 TPE2 HR	Thermowelded connector	Female-Straight	M12	8	8	2	WSOR
	CT M12/12 PUR5 HR	Thermowelded connector	Female-Straight	M12	12	12	5	PUR
	CT M12/4 PUR10 HR	Thermowelded connector	Female-Straight	M12	5	4	10	PUR
	CT M12/4 PVC2 HR	Thermowelded connector	Female-Straight	M12	5	4	2	PVC
	CT M12/4 TPE2 HR	Thermowelded connector	Female-Straight	M12	5	4	2	WSOR
	CT M12/12 PUR10 HR	Thermowelded connector	Female-Straight	M12	12	12	10	PUR
	CT M12/8 TPE10 HR	Thermowelded connector	Female-Straight	M12	8	8	10	WSOR
	CT M12/4 PUR5 HR LP	Thermowelded connector	Female-Straight	M12	5	4	5	PUR
		CT M12/4D TPE2 MC	Thermowelded connector	Male-Elbow	M12	4	4	2
CT M12/4D TPE5 MC		Thermowelded connector	Male-Elbow	M12	4	4	5	TPE
CT M12/4D TPE10 MC		Thermowelded connector	Male-Elbow	M12	4	4	10	TPE
	CT M12/4D TPE5 MR	Thermowelded connector	Male-Straight	M12	4	4	5	TPE
	CT M12/4D TPE10 MR	Thermowelded connector	Male-Straight	M12	4	4	10	TPE
	CT M12/4D TPE2 MR	Thermowelded connector	Male-Straight	M12	4	4	2	TPE

Notes

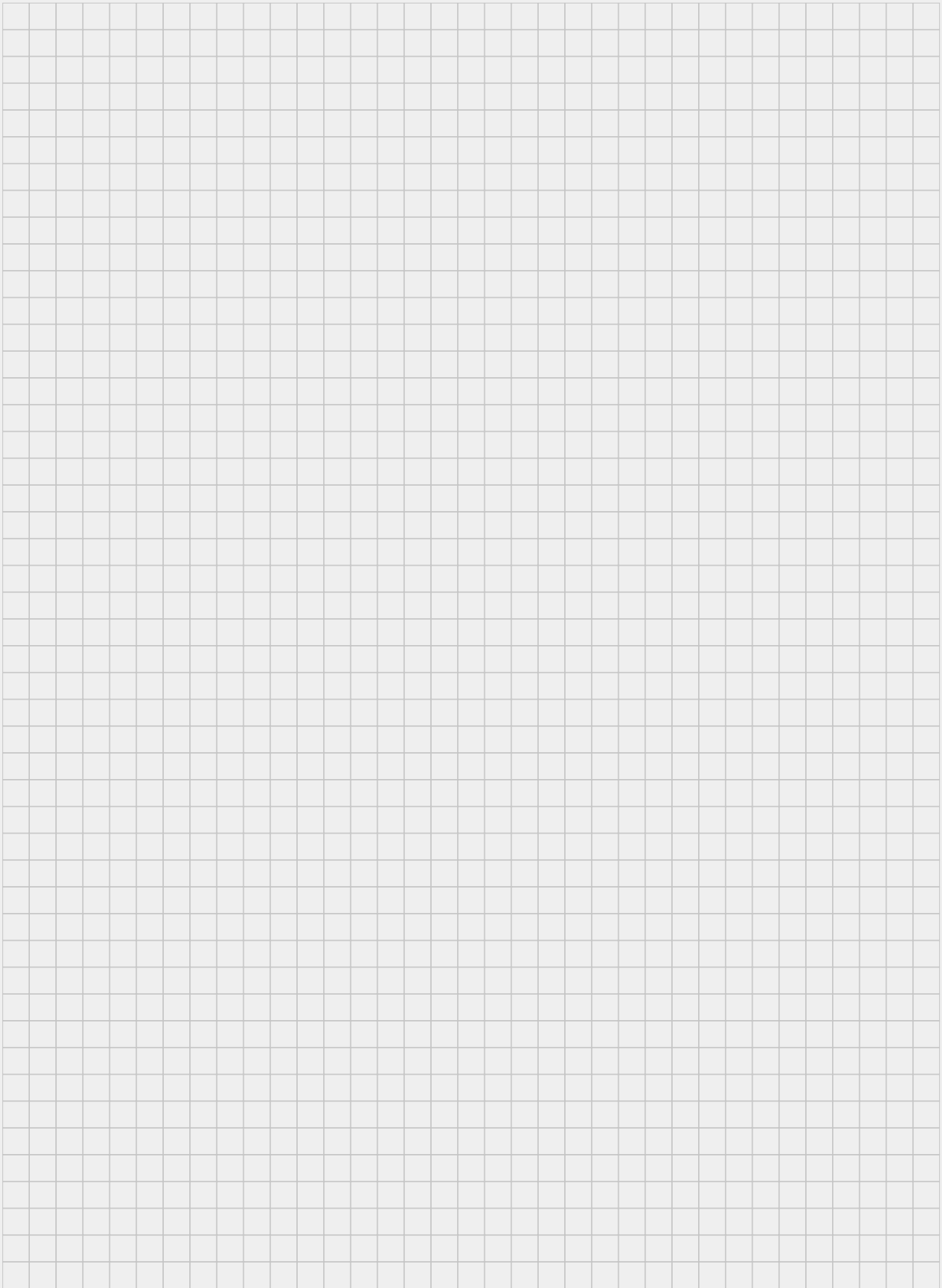

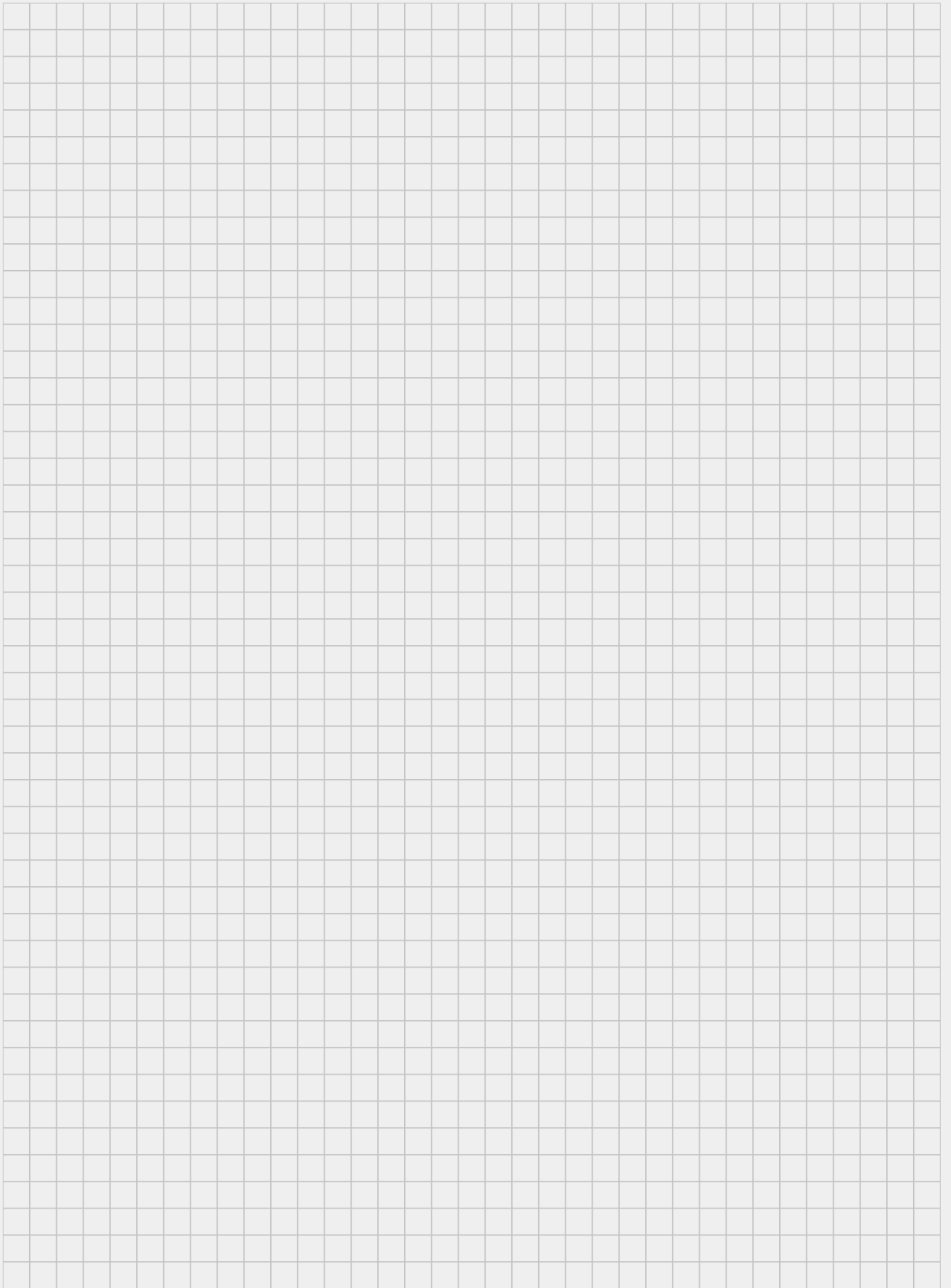



Instruments must not be used for safety purposes, particularly when the people's safety depends on the proper functioning of the instrument.

These instruments must only be used by qualified personnel.



"Functional safety of the product" test marks

The "Product safety, functional safety" test mark applies to products that require product or application functional safety standards for their use in safety related applications. Safe mode performance in accordance with a defined safety level (SIL, PL or other) must be tested in accordance with the relevant standards for all of these products.



CE conformity marking

The letters "CE" are to be found on a lot of products sold in the European Economic Area (EEA). They indicate that the products sold in the EEA have been assessed for compliance with high health, safety and environmental protection standards.



Waste Electrical and Electronic Equipment Directive (WEEE)

In the European Union, the symbol on this label indicates that this product must not be discarded with domestic waste. Midatec products are subject to this directive. Accordingly, they must be separated and taken to a suitable collection point in your town or province to enable their subsequent recovery and recycling. Consult local information on how to recycle electronic waste responsibly in your province.

We make sensors for industry

In pursuit of the perfect solution, Midatec designs, develops and manufactures sensors for industry, continuously striving to offer innovative and reliable products

+34 961 824 232
info@midatec.com

Further information on our products is
available at **midatec.com**



Quality Management Policy Principles:

- ▶ Customer satisfaction
- ▶ Continuous improvement
- ▶ Our staff is our main asset
- ▶ Commitment to the environmental aspects of our corporate activity



In the pursuit of its corporate activity, MIDATEC makes sure to comply with current legislation, seeks to prevent pollution and refrain from generating negative environmental impacts, thereby attesting to its respect for the environment.

Midatec
sensing the future



midatec.com